

# Workshop on Geometric Control of Mechanical Systems

Francesco Bullo and Andrew D. Lewis

13/12/2004

## Introduction

### Some sample systems

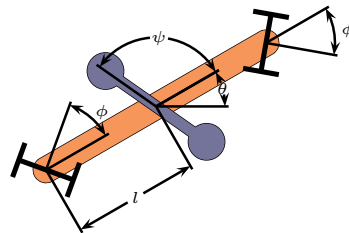
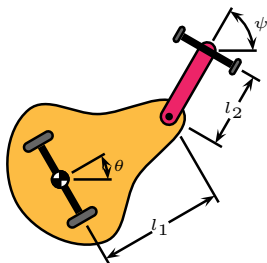
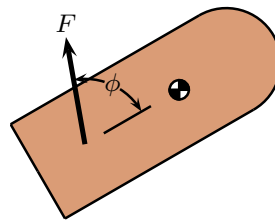
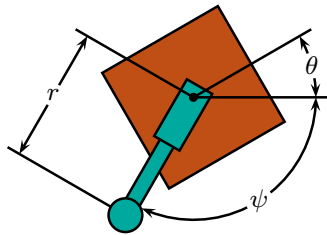

### Sample problems (vaguely)

- Modeling: Is it possible to model the four systems in a unified way, that allows for the development of effective analysis and design techniques?
- Analysis: Some of the usual things in control theory: stability, *controllability*, *perturbation methods*.
- Design: Again, some of the usual things: *motion planning*, *stabilization*, *trajectory tracking*.

### Sample problems (concretely)

Start from rest.

1. Describe the set of reachable *states*.
  - (a) Does it have a nonempty interior?
  - (b) If so, is the original state contained in the interior?
2. Describe the set of reachable *positions*.
3. Provide an algorithm to steer from one position at rest to another position at rest.
4. Provide a closed-loop algorithm for stabilizing a specified configuration at rest.
5. Repeat with thrust direction fixed.

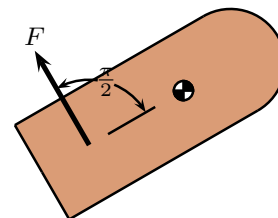
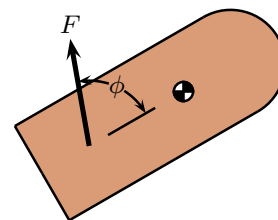

### The literature, historically

- *Abraham and Marsden [1978], Arnol'd [1978], Godbillon [1969]*: Geometrization of mechanics in the 1960's.
- *Agrachev and Sachkov [2004], Jurdjevic [1997], Nijmeijer and van der Schaft [1990]*: Geometrization of control theory in the 1970's, 80's, and 90's by Agrachev, Brockett, Hermes, Krener, Sussmann, and many others.
- *Brockett [1977]*: Lagrangian and Hamiltonian formalisms, controllability, passivity, some good examples.
- *Crouch [1981]*: Geometric structures in control systems.
- *van der Schaft [1981/82, 1982, 1983, 1985, 1986]*: A fully-developed Hamiltonian foray: modeling, controllability, stabilization.
- *Takegaki and Arimoto [1981]*: Potential-shaping for stabilization.
- *Bonnard [1984]*: Lie groups and controllability.

### The literature, historically (cont'd)

- *Bloch and Crouch [1992]*: Affine connections in control theory, controllability.
- *Bates and Śniatycki [1993], Bloch, Krishnaprasad, Marsden, and Murray [1996], Koiller [1992], van der Schaft and Maschke [1994]*: Geometrization of systems with constraints.
- *Bloch, Reyhanoglu, and McClamroch [1992]*: Controllability for systems with constraints.
- *Baillieul [1993]*: Vibrational stabilization.
- *Arimoto [1996], Ortega, Loria, Nicklasson, and Sira-Ramirez [1998]*: Texts on stabilization using passivity methods.
- *Bloch, Chang, Leonard, and Marsden [2001], Bloch, Leonard, and Marsden [2000], Ortega, Spong, Gómez-Estern, and Blankenstein [2002]*: Energy shaping.
- *Bloch [2003]*: Text on mechanics and control.

### The literature, historically (cont'd) Today's topics.

- *Lewis and Murray [1997]*: Controllability.
- *Bullo and Lewis [2003], Bullo and Lynch [2001]*: Low-order controllability, kinematic reduction, and motion planning.
- *Bullo [2001, 2002]*: Series expansions, averaging, vibrational stabilization.
- *Martínez, Cortés, and Bullo [2003]*: Trajectory tracking using oscillatory controls.

### What we will try to do today

- Present a unified methodology for modeling, analysis, and design for mechanical control systems.
- The methodology is differential geometric, generally speaking, and affine differential geometric, more specifically speaking. Follows:
  - *Geometric Control of Mechanical Systems: Modeling, Analysis, and Design for Simple Mechanical Control Systems*  
Francesco Bullo and Andrew D. Lewis  
Springer–Verlag, 2004
- *Warning!* We will be much less precise during the workshop than we are in the book.
- We make no claims that the methodology presented is better than alternative approaches.

## Geometric modeling of mechanical systems

Differential geometry essential:

### Advantages

1. Prevents artificial reliance on specific coordinate systems.
2. Identifies key elements of system model.
3. Suggests methods of analysis and design.

### Disadvantages

1. Need to know differential geometry.

### Manifolds

- **Manifold**  $M$ , covered with **charts**  $\{(\mathcal{U}_a, \phi_a)\}_{a \in A}$  satisfying **overlap condition**.
- Around any point  $x \in M$  a chart  $(\mathcal{U}, \phi)$  provides **coordinates**  $(x^1, \dots, x^n)$ .
- Continuity and differentiability are checked in coordinates as usual.

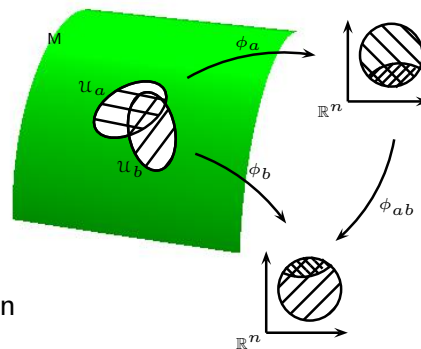

**Manifolds (cont'd)** Manifolds we will use today.

1. **Euclidean space:**  $\mathbb{R}^n$ .
2. **n-dimensional sphere:**  $\mathbb{S}^n = \{\mathbf{x} \in \mathbb{R}^{n+1} \mid \|\mathbf{x}\|_{\mathbb{R}^{n+1}} = 1\}$ .
3. **m × n matrices:**  $\mathbb{R}^{m \times n}$ .
4. **General linear group:**  $\text{GL}(n; \mathbb{R}) = \{\mathbf{A} \in \mathbb{R}^{n \times n} \mid \det \mathbf{A} \neq 0\}$ .
5. **Special orthogonal group:**  
 $\text{SO}(n) = \{\mathbf{R} \in \text{GL}(n; \mathbb{R}) \mid \mathbf{R}\mathbf{R}^T = \mathbf{I}_n, \det \mathbf{R} = 1\}$ .
6. **Special Euclidean group:**  $\text{SE}(n) = \text{SO}(n) \times \mathbb{R}^n$ .

The manifolds  $\mathbb{S}^n$ ,  $\text{GL}(n; \mathbb{R})$ , and  $\text{SO}(n)$  are examples of **submanifolds**, meaning (roughly) that they are manifolds contained in another manifold, and acquiring their manifold structure from the larger manifold (think surface).

### Tangent bundles

- Formalize the idea of “velocity.”
- Given a curve  $t \mapsto \gamma(t)$  represented in coordinates by  $t \mapsto (x^1(t), \dots, x^n(t))$ , its “velocity” is  $t \mapsto (\dot{x}^1(t), \dots, \dot{x}^n(t))$ .
- **Tangent vectors** are equivalence classes of curves.
- The **tangent space** at  $x \in M$ :  $T_x M = \{\text{tangent vector at } x\}$ .
- The **tangent bundle** of  $M$ :  $\text{TM} = \cup_{x \in M} T_x M$ .
- The tangent bundle is a manifold with natural coordinates denoted by  $((x^1, \dots, x^n), (v^1, \dots, v^n))$ .

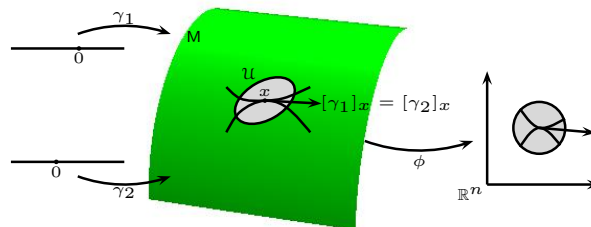

## Vector fields

- Assign to each point  $x \in M$  an element of  $T_x M$ .
- Coordinates  $(x^1, \dots, x^n)$   
 → vector fields  $\{\frac{\partial}{\partial x^1}, \dots, \frac{\partial}{\partial x^n}\}$  on chart domain.
- → Any vector field  $X$  is given in coordinates by  $X = X^i \frac{\partial}{\partial x^i}$  (note use of **summation convention**).

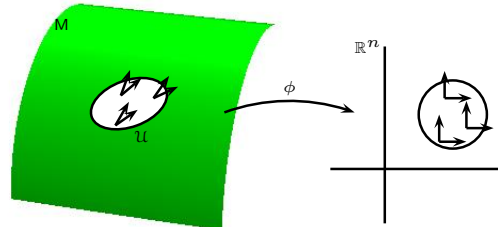

## Flows

- Vector field  $X$  and chart  $(\mathcal{U}, \phi)$  → o.d.e.:

$$\dot{x}^1(t) = X^1(x^1(t), \dots, x^n(t))$$

$$\vdots$$

$$\dot{x}^n(t) = X^n(x^1(t), \dots, x^n(t)).$$

- Solution of o.d.e. ↔ curve  $t \mapsto \gamma(t)$  satisfying  $\gamma'(t) = X(\gamma(t))$ .
- Such curves are **integral curves** of  $X$ .
- **Flow** of  $X$ :  $(t, x) \mapsto \Phi_t^X(x)$  where  $t \mapsto \Phi_t^X(x)$  is the integral curve of  $X$  through  $x$ .

### Lie bracket

- Flows do not generally commute.
- i.e., given  $X$  and  $Y$ , it is not generally true that  $\Phi_t^X \circ \Phi_s^Y = \Phi_s^Y \circ \Phi_t^X$ .
- The **Lie bracket** of  $X$  and  $Y$ :

$$[X, Y](x) = \left. \frac{d}{dt} \right|_{t=0} \Phi_{\sqrt{t}}^{-Y} \circ \Phi_{\sqrt{t}}^{-X} \circ \Phi_{\sqrt{t}}^Y \circ \Phi_{\sqrt{t}}^X(x).$$

Measures the manner in which flows do not commute.

### Mechanical exhibition of the Lie bracket

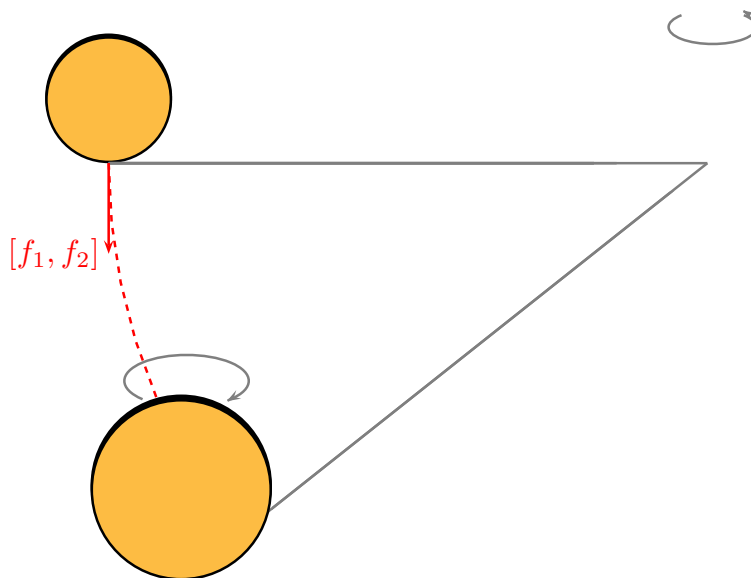

## Vector fields as differential operators

- Vector field  $X$  and function  $f: M \rightarrow \mathbb{R} \longrightarrow$  **Lie derivative** of  $f$  with respect to  $X$ :

$$\mathcal{L}_X f(x) = \left. \frac{d}{dt} \right|_{t=0} f(\Phi_t^X(x)).$$

- In coordinates:  $\mathcal{L}_X f = X^i \frac{\partial f}{\partial x^i}$  (directional derivative).
- One can show that  $\mathcal{L}_X \mathcal{L}_Y f - \mathcal{L}_Y \mathcal{L}_X f = \mathcal{L}_{[X,Y]} f$

$$\longrightarrow [X, Y] = \left( \frac{\partial Y^i}{\partial x^j} X^j - \frac{\partial X^i}{\partial x^j} Y^j \right) \frac{\partial}{\partial x^i}.$$

## Configuration manifold

- Single rigid body:

$$\begin{array}{l} \text{positions} \\ \text{of body} \end{array} \longleftrightarrow \begin{array}{l} (O_{\text{body}} - O_{\text{spatial}}) \in \mathbb{R}^3 \\ \left[ \begin{array}{c|c|c} \mathbf{b}_1 & \mathbf{b}_2 & \mathbf{b}_3 \end{array} \right] \in \text{SO}(3). \end{array}$$

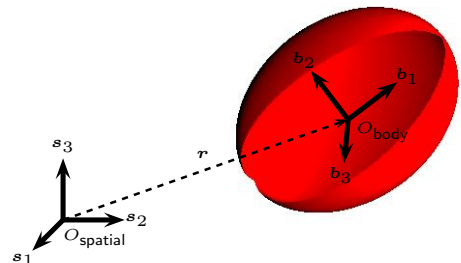

- $Q = \text{SO}(3) \times \mathbb{R}^3$  for a single rigid body.
- For  $k$  rigid bodies,

$$Q_{\text{free}} = \underbrace{(\text{SO}(3) \times \mathbb{R}^3) \times \cdots \times (\text{SO}(3) \times \mathbb{R}^3)}_{k \text{ copies}}$$

This is a **free mechanical system**.

### Configuration manifold (cont'd)

- Most systems are not free, but consist of bodies that are interconnected.

**Definition 1** An **interconnected mechanical system** is a collection  $\mathcal{B}_1, \dots, \mathcal{B}_k$  of rigid bodies restricted to move on a submanifold  $Q$  of  $Q_{\text{free}}$ . The manifold  $Q$  is the **configuration manifold**.

- Coordinates for  $Q$  are denoted by  $(q^1, \dots, q^n)$ . Often called “generalized coordinates.”
- For  $j \in \{1, \dots, k\}$ ,  $\Pi_j: Q \rightarrow \text{SO}(3) \times \mathbb{R}^3$  gives configuration of  $j$ th body. This is the **forward kinematic map**.

### Configuration manifold (cont'd)

**Example 2** *Planar rigid body:*

- $Q = \text{SO}(2) \times \mathbb{R}^2 \simeq \mathbb{S}^1 \times \mathbb{R}^2$ .
- Coordinates  $(\theta, x, y)$ .

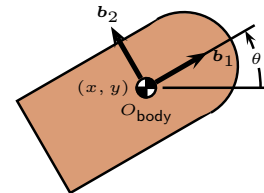
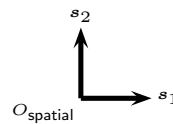

- 

$$\Pi_1(\theta, x, y) = \left( \underbrace{\begin{bmatrix} \cos \theta & -\sin \theta & 0 \\ \sin \theta & \cos \theta & 0 \\ 0 & 0 & 1 \end{bmatrix}}_{=R_1 \in \text{SO}(3)}, \underbrace{(x, y, 0)}_{=r_1 \in \mathbb{R}^3} \right).$$

**Configuration manifold (cont'd)**

**Example 3** *Two-link manipulator:*

- $Q = SO(2) \times SO(2) \simeq S^1 \times S^1$ .
- Coordinates  $(\theta_1, \theta_2)$ .
- $\Pi_1(\theta_1, \theta_2) = (\mathbf{R}_1, \mathbf{r}_1)$  and  $\Pi_2(\theta_1, \theta_2) = (\mathbf{R}_2, \mathbf{r}_2)$ , where

$$\mathbf{R}_1 = \begin{bmatrix} \cos \theta_1 & -\sin \theta_1 & 0 \\ \sin \theta_1 & \cos \theta_1 & 0 \\ 0 & 0 & 1 \end{bmatrix}, \quad \mathbf{R}_2 = \begin{bmatrix} \cos \theta_2 & -\sin \theta_2 & 0 \\ \sin \theta_2 & \cos \theta_2 & 0 \\ 0 & 0 & 1 \end{bmatrix},$$

$$\mathbf{r}_1 = r_1 \mathbf{R}_1 \mathbf{s}_1, \quad \mathbf{r}_2 = \ell_1 \mathbf{R}_1 \mathbf{s}_1 + r_2 \mathbf{R}_2 \mathbf{s}_1.$$

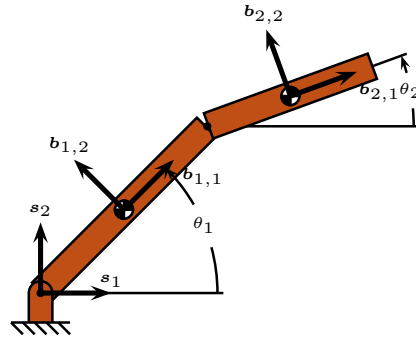

**Configuration manifold (cont'd)**

**Example 4** *Rolling disk:*

- $Q = \mathbb{R}^2 \times S^1 \times S^1$ .
- Coordinates  $(x, y, \theta, \phi)$ .
- 

$$\Pi_1(x, y, \theta, \phi) = \left( \underbrace{\begin{bmatrix} \cos \phi \cos \theta & \sin \phi \cos \theta & \sin \theta \\ \cos \phi \sin \theta & \sin \phi \sin \theta & -\cos \theta \\ -\sin \phi & \cos \phi & 0 \end{bmatrix}}_{=\mathbf{R}_1 \in SO(3)}, \underbrace{(x, y, \rho)}_{=\mathbf{r}_1 \in \mathbb{R}^3} \right).$$

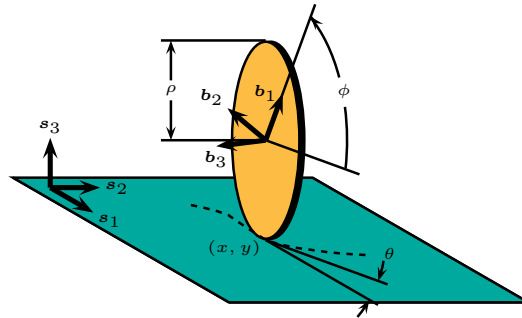

## Velocity

- Rigid body  $\mathcal{B}$  undergoing motion  $t \mapsto (\mathbf{R}(t), \mathbf{r}(t))$ :
  1. **Translational velocity:**  $t \mapsto \dot{\mathbf{r}}(t)$ ;
  2. **Spatial angular velocity:**  $t \mapsto \widehat{\boldsymbol{\omega}}(t) \triangleq \dot{\mathbf{R}}(t)\mathbf{R}^{-1}(t)$ ;
  3. **Body angular velocity:**  $t \mapsto \widehat{\boldsymbol{\Omega}}(t) \triangleq \mathbf{R}^{-1}(t)\dot{\mathbf{R}}(t)$ .
- Both  $\widehat{\boldsymbol{\omega}}(t)$  and  $\widehat{\boldsymbol{\Omega}}(t)$  lie in  $\mathfrak{so}(3)$   $\longrightarrow$  define  $\boldsymbol{\omega}(t), \boldsymbol{\Omega}(t) \in \mathbb{R}^3$  by the rule

$$\begin{bmatrix} 0 & -a^3 & a^2 \\ a^3 & 0 & -a^1 \\ -a^2 & a^1 & 0 \end{bmatrix} \longleftrightarrow (a^1, a^2, a^3).$$

## Inertia tensor

- Rigid body  $\mathcal{B}$  with mass distribution  $\mu$ .
- **Mass:**  $\mu(\mathcal{B}) = \int_{\mathcal{B}} d\mu$ .
- **Centre of mass:**  $\mathbf{x}_c = \int_{\mathcal{B}} \mathbf{x} d\mu$ .
- **Inertia tensor** about  $\mathbf{x}_c$ :  $\mathbb{I}_c: \mathbb{R}^3 \rightarrow \mathbb{R}^3$  defined by

$$\mathbb{I}_c(\mathbf{v}) = \int_{\mathcal{B}} (\mathbf{x} - \mathbf{x}_c) \times (\mathbf{v} \times (\mathbf{x} - \mathbf{x}_c)) d\mu.$$

### Kinetic energy

- Rigid body  $\mathcal{B}$  undergoing motion  $t \mapsto (\mathbf{R}(t), \mathbf{r}(t))$ .
- Assume  $O_{\text{body}}$  is at the center of mass ( $\mathbf{x}_c = \mathbf{0}$ ).
- **Kinetic energy:**

$$\text{KE}(t) = \frac{1}{2} \int_{\mathcal{B}} \|\dot{\mathbf{r}}(t) + \dot{\mathbf{R}}(t)\mathbf{x}\|_{\mathbb{R}^3}^2 d\mu$$

**Proposition 5**  $\text{KE}(t) = \text{KE}_{\text{trans}}(t) + \text{KE}_{\text{rot}}(t)$  where

$$\text{KE}_{\text{trans}}(t) = \frac{1}{2} \mu(\mathcal{B}) \|\dot{\mathbf{r}}(t)\|_{\mathbb{R}^3}^2, \quad \text{KE}_{\text{rot}} = \frac{1}{2} \langle \mathbb{I}_c(\boldsymbol{\Omega}(t)), \boldsymbol{\Omega}(t) \rangle_{\mathbb{R}^3}.$$

### Kinetic energy (cont'd)

- Interconnected mechanical system with configuration manifold  $\mathcal{Q}$ .
- $v_q \in \text{TQ}$ .
- $t \mapsto \gamma(t) \in \mathcal{Q}$  a motion for which  $\gamma'(0) = v_q$ .
- $j$ th body undergoes motion  $t \mapsto \Pi_j \circ \gamma(t) = (\mathbf{R}_j(t), \mathbf{r}_j(t))$ .
- Define  $\hat{\boldsymbol{\Omega}}_j(t) = \mathbf{R}_j^{-1}(t) \dot{\mathbf{R}}_j(t)$ .
- Define  $\text{KE}_j(v_q) = \frac{1}{2} \mu_j(\mathcal{B}_j) \|\dot{\mathbf{r}}_j(0)\|_{\mathbb{R}^3}^2 + \frac{1}{2} \langle \mathbb{I}_{j,c}(\boldsymbol{\Omega}_j(0)), \boldsymbol{\Omega}_j(0) \rangle_{\mathbb{R}^3}$ .
- This defines a function  $\text{KE}_j: \text{TQ} \rightarrow \mathbb{R}$  which gives the kinetic energy of the  $j$ th body.
- The **kinetic energy** is the function  $\text{KE}(v_q) = \sum_{j=1}^k \text{KE}_j(v_q)$ .

## Symmetric bilinear maps

- Need a little algebra to describe KE.
- Let  $V$  be a  $\mathbb{R}$ -vector space.  $\Sigma_2(V)$  is the set of maps  $B: V \times V \rightarrow \mathbb{R}$  such that
  1.  $B$  is bilinear and
  2.  $B(v_1, v_2) = B(v_2, v_1)$ .
- Basis  $\{e_1, \dots, e_n\}$  for  $V$ :  $B_{ij} = B(e_i, e_j)$ ,  $i, j \in \{1, \dots, n\}$ , are **components** of  $B$ .
- $[B]$  is the **matrix representative** of  $B$ .
- An **inner product** on  $V$  is an element  $\mathbb{G}$  of  $\Sigma_2(V)$  with the property that  $\mathbb{G}(v, v) \geq 0$  and  $\mathbb{G}(v, v) = 0$  if and only if  $v = 0$ .

**Example 6**  $V = \mathbb{R}^n$ ,  $\mathbb{G}_{\mathbb{R}^n}$  the standard inner product,  $\{e_1, \dots, e_n\}$  the standard basis:  $(\mathbb{G}_{\mathbb{R}^n})_{ij} = \delta_{ij}$ . •

## Kinetic energy metric

**Proposition 7** *There exists an assignment  $q \mapsto \mathbb{G}(q)$  of an inner product on  $T_q Q$  with the property that  $\text{KE}(v_q) = \frac{1}{2} \mathbb{G}(q)(v_q, v_q)$ .*

- $\mathbb{G}$  is the **kinetic energy metric** and is an example of a **Riemannian metric**.
- $\mathbb{G}$  is a crucial element in any geometric model of a mechanical system.

## Kinetic energy metric (cont'd)

**Example 8** *Planar rigid body:*

$$\mathbb{I}_{1,c} = \begin{bmatrix} * & * & 0 \\ * & * & 0 \\ 0 & 0 & J \end{bmatrix}, \quad \boldsymbol{\Omega}_1(t) = (\mathbf{R}_1^{-1}(t)\dot{\mathbf{R}}_1)^\vee = (0, 0, \dot{\theta}),$$

$$\longrightarrow \text{KE} = \frac{1}{2}m(\dot{x}^2 + \dot{y}^2) + \frac{1}{2}J\dot{\theta}^2,$$

$$\longrightarrow [\mathbb{G}] = \begin{bmatrix} J & 0 & 0 \\ 0 & m & 0 \\ 0 & 0 & m \end{bmatrix}.$$

## Kinetic energy metric (cont'd)

**Example 9** *Two-link manipulator:*

$$\mathbb{I}_{1,c} = \begin{bmatrix} * & * & 0 \\ * & * & 0 \\ 0 & 0 & J_1 \end{bmatrix}, \quad \mathbb{I}_{2,c} = \begin{bmatrix} * & * & 0 \\ * & * & 0 \\ 0 & 0 & J_2 \end{bmatrix},$$

$$\boldsymbol{\Omega}_1(t) = (\mathbf{R}_1^{-1}(t)\dot{\mathbf{R}}_1)^\vee = (0, 0, \dot{\theta}_1),$$

$$\boldsymbol{\Omega}_2(t) = (\mathbf{R}_2^{-1}(t)\dot{\mathbf{R}}_2)^\vee = (0, 0, \dot{\theta}_2),$$

$$\longrightarrow \text{KE} = \frac{1}{8}(m_1 + 4m_2)\ell_1^2\dot{\theta}_1^2 + \frac{1}{8}m_2\ell_2^2\dot{\theta}_2^2 \\ + \frac{1}{2}m_2\ell_1\ell_2 \cos(\theta_1 - \theta_2)\dot{\theta}_1\dot{\theta}_2 + \frac{1}{2}J_1\dot{\theta}_1^2 + \frac{1}{2}J_2\dot{\theta}_2^2,$$

$$\longrightarrow [\mathbb{G}] = \begin{bmatrix} J_1 + \frac{1}{4}(m_1 + 4m_2)\ell_1^2 & \frac{1}{2}m_2\ell_1\ell_2 \cos(\theta_1 - \theta_2) \\ \frac{1}{2}m_2\ell_1\ell_2 \cos(\theta_1 - \theta_2) & J_2 + \frac{1}{4}m_2\ell_2^2 \end{bmatrix}.$$

## Kinetic energy metric (cont'd)

**Example 10** *Rolling disk:*

$$\mathbb{I}_{1,c} = \begin{bmatrix} J_{\text{spin}} & 0 & 0 \\ 0 & J_{\text{spin}} & 0 \\ 0 & 0 & J_{\text{roll}} \end{bmatrix}, \quad \boldsymbol{\Omega}_1(t) = (\mathbf{R}_1^{-1}(t)\dot{\mathbf{R}}_1)^\vee = (-\dot{\theta} \sin \phi, \dot{\theta} \cos \phi, -\dot{\phi}),$$

$$\rightarrow \text{KE} = \frac{1}{2}m(\dot{x}^2 + \dot{y}^2) + \frac{1}{2}J_{\text{spin}}\dot{\theta}^2 + \frac{1}{2}J_{\text{roll}}\dot{\phi}^2,$$

$$\rightarrow [\mathbb{G}] = \begin{bmatrix} m & 0 & 0 & 0 \\ 0 & m & 0 & 0 \\ 0 & 0 & J_{\text{spin}} & 0 \\ 0 & 0 & 0 & J_{\text{roll}} \end{bmatrix}.$$

•

## Kinetic energy metric (cont'd)

- This whole procedure can be automated in a symbolic manipulation language.
- *Snakeboard* example:

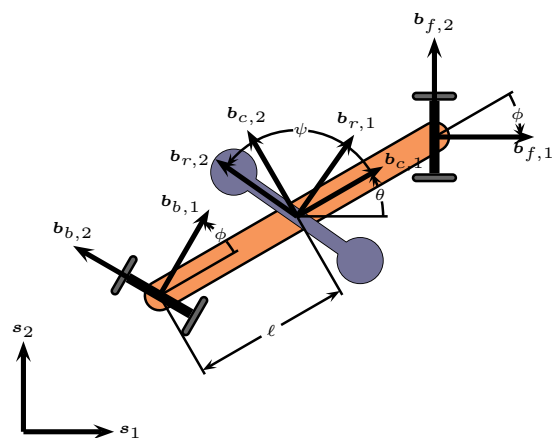

- Here  $Q = \mathbb{R}^2 \times \mathbb{S}^1 \times \mathbb{S}^1 \times \mathbb{S}^1$  with coordinates  $(x, y, \theta, \psi, \phi)$ .

## Euler-Lagrange equations

- Free mechanical system with configuration manifold  $Q$  and kinetic energy metric  $\mathbb{G}$ .
- *Question:* What are the governing equations?
- *Answer:* The Euler–Lagrange equations.
- Define the **Lagrangian**  $L(v_q) = \frac{1}{2}\mathbb{G}(v_q, v_q)$ .
- Choose local coordinates  $((q^1, \dots, q^n), (v^1, \dots, v^n))$  for TQ.
- The **Euler–Lagrange equations** are

$$\frac{d}{dt} \left( \frac{\partial L}{\partial v^i} \right) - \frac{\partial L}{\partial q^i} = 0, \quad i \in \{1, \dots, n\}.$$

- The Euler–Lagrange equations are “first-order” necessary conditions for the solution of a certain variational problem.

## Euler–Lagrange equations

- Let us expand the Euler–Lagrange equations for  $L = \frac{1}{2}\mathbb{G}_{ij}(q)\dot{q}^i\dot{q}^j$ :

$$\begin{aligned} \frac{d}{dt} \left( \frac{\partial L}{\partial v^i} \right) - \frac{\partial L}{\partial q^i} &= \mathbb{G}_{ij} \left( \ddot{q}^j + \mathbb{G}^{jk} \left( \frac{\partial \mathbb{G}_{kl}}{\partial q^m} - \frac{1}{2} \frac{\partial \mathbb{G}_{lm}}{\partial q^k} \right) \dot{q}^l \dot{q}^m \right) \\ &= \mathbb{G}_{ij} \left( \ddot{q}^j + \overset{\mathbb{G}}{\Gamma}_{lm}^j \dot{q}^l \dot{q}^m \right), \end{aligned}$$

where

$$\overset{\mathbb{G}}{\Gamma}_{jk}^i = \frac{1}{2} \mathbb{G}^{il} \left( \frac{\partial \mathbb{G}_{lj}}{\partial q^k} + \frac{\partial \mathbb{G}_{lk}}{\partial q^j} - \frac{\partial \mathbb{G}_{jk}}{\partial q^l} \right), \quad i, j, k \in \{1, \dots, n\}.$$

- *Question:* What are these functions  $\overset{\mathbb{G}}{\Gamma}_{jk}^i$ ?

## Affine connections

**Definition 11** An **affine connection** on  $Q$  is an assignment to each pair of vector fields  $X$  and  $Y$  on  $Q$  of a vector field  $\nabla_X Y$ , where the assignment satisfies:

- (i)  $(X, Y) \mapsto \nabla_X Y$  is  $\mathbb{R}$ -bilinear;
- (ii)  $\nabla_{fX} Y = f\nabla_X Y$  for all vector fields  $X$  and  $Y$ , and all functions  $f$ ;
- (iii)  $\nabla_X(fY) = f\nabla_X Y + (\mathcal{L}_X f)Y$  for all vector fields  $X$  and  $Y$ , and all functions  $f$ .

The vector field  $\nabla_X Y$  is the **covariant derivative** of  $Y$  with respect to  $X$ . •

## Affine connections (cont'd)

- **Question:** What really “characterizes”  $\nabla$ ?
- **Coordinate answer:** Let  $(q^1, \dots, q^n)$  be coordinates. Define  $n^3$  functions  $\Gamma_{jk}^i$ ,  $i, j, k \in \{1, \dots, n\}$ , on the chart domain by

$$\nabla_{\frac{\partial}{\partial q^j}} \frac{\partial}{\partial q^k} = \Gamma_{jk}^i \frac{\partial}{\partial q^i}, \quad j, k \in \{1, \dots, n\}.$$

- $\Gamma_{jk}^i$ ,  $i, j, k \in \{1, \dots, n\}$ , are the **Christoffel symbols** for  $\nabla$  in the given coordinates.

### Affine connections (cont'd)

- A connection is “completely determined” by its Christoffel symbols:

$$\nabla_X Y = \left( \frac{\partial Y^i}{\partial q^j} X^j + \Gamma_{jk}^i X^j Y^k \right) \frac{\partial}{\partial q^i}.$$

**Theorem 12** Let  $\mathbb{G}$  be a Riemannian metric on a manifold  $Q$ . Then there exists a unique affine connection  $\overset{\mathbb{G}}{\nabla}$ , called the **Levi-Civita connection**, such that

(i)  $\mathcal{L}_X(\mathbb{G}(Y, Z)) = \mathbb{G}(\overset{\mathbb{G}}{\nabla}_X Y, Z) + \mathbb{G}(Y, \overset{\mathbb{G}}{\nabla}_X Z)$  and

(ii)  $\overset{\mathbb{G}}{\nabla}_X Y - \overset{\mathbb{G}}{\nabla}_Y X = [X, Y]$ .

Furthermore, the Christoffel symbols of  $\overset{\mathbb{G}}{\nabla}$  are  $\overset{\mathbb{G}}{\Gamma}_{jk}^i$ ,  $i, j, k \in \{1, \dots, n\}$ .

### Return to Euler–Lagrange equations

- Had shown that

$$\frac{d}{dt} \left( \frac{\partial L}{\partial v^i} \right) - \frac{\partial L}{\partial q^i} = 0 \iff \ddot{q}^i + \overset{\mathbb{G}}{\Gamma}_{jk}^i \dot{q}^j \dot{q}^k = 0.$$

- Interpretation of  $\ddot{q}^i + \overset{\mathbb{G}}{\Gamma}_{jk}^i \dot{q}^j \dot{q}^k$ .

1. Covariant derivative of  $\gamma'$  with respect to itself:

$$\nabla_{\gamma'(t)} \gamma'(t) = (\ddot{q}^i + \overset{\mathbb{G}}{\Gamma}_{jk}^i \dot{q}^j \dot{q}^k) \frac{\partial}{\partial q^i}.$$

2. Curves  $t \mapsto \gamma(t)$  satisfying  $\nabla_{\gamma'(t)} \gamma'(t) = 0$  are **geodesics** and can be thought of as being “acceleration free.”

3. Mechanically,  $\underbrace{\nabla_{\gamma'(t)} \gamma'(t)}_{\text{acc'n}} = \underbrace{0}_{\substack{\text{force} \\ \text{mass}}}$ .

- “Bottom-line”:  $\overset{\mathbb{G}}{\nabla}_{\gamma'(t)} \gamma'(t)$  can be computed, and gives access to significant mathematical tools.

## Forces

- Some linear algebra: If  $V$  is a  $\mathbb{R}$ -vector space,  $V^*$  is the set of linear maps from  $V$  to  $\mathbb{R}$ . This is the **dual space** of  $V$ .
- Denote  $\alpha(v) = \langle \alpha; v \rangle$  for  $\alpha \in V^*$  and  $v \in V$ .
- If  $\{e_1, \dots, e_n\}$  is a basis for  $V$ , the **dual basis** for  $V^*$  is denoted by  $\{e^1, \dots, e^n\}$  and defined by  $e^i(e_j) = \delta_j^i$ .
- The dual space of  $T_q Q$  is denoted by  $T_q^* Q$ , and called the **cotangent space**.
- The **dual basis** to  $\{\frac{\partial}{\partial q^1}, \dots, \frac{\partial}{\partial q^n}\}$  is denoted by  $\{dq^1, \dots, dq^n\}$ .
- A **covector field** assigns to each point  $q \in Q$  an element of  $T_q^* Q$ .

**Example 13** The **differential** of a function is  $df(q) \in T_q^* Q$  defined by  $\langle df(q); X(q) \rangle = \mathcal{L}_X f(q)$ . In coordinates,  $df = \frac{\partial f}{\partial q^i} dq^i$ .

## Forces (cont'd)

- Newtonian forces on a rigid body: force  $f$  applied to the center of mass and a pure torque  $\tau$ .
- Need to add these to the Euler–Lagrange equations in the right way.
- Use the idea of infinitesimal work done by a (say) force  $f$  in the direction  $w$ :  $\langle f, w \rangle_{\mathbb{R}^3}$ .
- For torques, the analogue is  $\langle \tau, \omega \rangle_{\mathbb{R}^3}$  where  $\hat{\omega}$  is the spatial representation of the angular velocity.
- Interconnected mechanical system with configuration manifold  $Q$ ,  $q \in Q$ ,  $w_q \in T_q Q$ .  $\longrightarrow$  Determine force as element of  $T_q^* Q$  by its action on  $w_q$ .

### Forces (cont'd)

- Fix body  $j$  with Newtonian force  $\mathbf{f}_j$  and torque  $\boldsymbol{\tau}_j$ .
- Let  $t \mapsto \gamma(t)$  satisfy  $\dot{\gamma}(0) = w_q$ , and let  $t \mapsto (\mathbf{R}_j(t), \mathbf{r}_j(t)) = \Pi_j \circ \gamma(t)$ .
- Let  $\hat{\boldsymbol{\omega}}_j(t) = \dot{\mathbf{R}}_j(t) \mathbf{R}_j^{-1}(t)$  be the spatial angular velocity.
- Define  $F_{\mathbf{f}_j, \boldsymbol{\tau}_j} \in \mathbb{T}_q^* \mathbb{Q}$  by

$$\langle F_{\mathbf{f}_j, \boldsymbol{\tau}_j}; w_q \rangle = \langle \mathbf{f}_j, \dot{\mathbf{r}}_j(0) \rangle_{\mathbb{R}^3} + \langle \boldsymbol{\tau}_j, \boldsymbol{\omega}_j(0) \rangle_{\mathbb{R}^3}.$$

- Sum over all bodies to get **total external force**  $F \in \mathbb{T}_q^* \mathbb{Q}$ :  $F = \sum_{j=1}^k F_{\mathbf{f}_j, \boldsymbol{\tau}_j}$ .

### Forces (cont'd)

- Note that the forces may depend on time (e.g., control forces) and velocity (e.g., dissipative forces).

→ A **force** is a map  $F: \mathbb{R} \times \mathbb{T}\mathbb{Q} \rightarrow \mathbb{T}^*\mathbb{Q}$  satisfying  $F(t, v_q) \in \mathbb{T}_q^* \mathbb{Q}$ .

- Thus can write  $F = F_i(t, q, v) dq^i$ .
- **Question:** How do forces appear in the Euler–Lagrange equations?
- **Answer:** Like this:

$$\frac{d}{dt} \left( \frac{\partial L}{\partial v^i} \right) - \frac{\partial L}{\partial q^i} = F_i.$$

*Why?* Because this agrees with Newton.

### Forces (cont'd)

- Given a force  $F: \mathbb{R} \times TQ \rightarrow T^*Q$ , define a **vector force**  $\mathbb{G}^\sharp(F): \mathbb{R} \times TQ \rightarrow TQ$  by

$$\mathbb{G}(\mathbb{G}^\sharp(F)(t, v_q), w_q) = \langle F(t, v_q); w_q \rangle.$$

- In coordinates,  $\mathbb{G}^\sharp(F) = \mathbb{G}^{ij} F_j \frac{\partial}{\partial q^i}$ .
- The Euler–Lagrange equations subject to force  $F$  are then equivalent to

$$\underbrace{\overset{\mathbb{G}}{\nabla}_{\gamma'(t)} \gamma'(t)}_{\text{acc'n}} = \underbrace{\mathbb{G}^\sharp(F)(t, \gamma'(t))}_{\substack{\text{force} \\ \text{mass}}}$$

### Forces (cont'd)

**Example 14** *Planar rigid body:*

$$\mathbf{f}_{1,1} = F(\cos(\theta + \phi), \sin(\theta + \phi), 0),$$

$$\boldsymbol{\tau}_{1,1} = F(0, 0, -h \sin \phi),$$

$$\mathbf{f}_{2,1} = (0, 0, 0), \quad \boldsymbol{\tau}_{2,1} = \tau(0, 0, 1),$$

$$\longrightarrow F^1 = F(\cos(\theta + \phi)dx + \sin(\theta + \phi)dy - h \sin \phi d\theta),$$

$$F^2 = \tau d\theta.$$

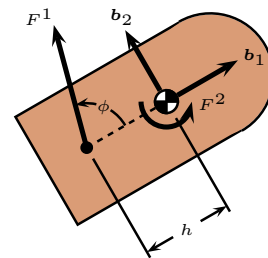

Equations of motion easily computed. •

**Forces (cont'd)**

**Example 15** *Two-link manipulator:*

$$\begin{aligned} \tau_{1,1} &= \tau_1(0, 0, 1), & \tau_{1,2} &= (0, 0, 0), \\ \tau_{2,1} &= -\tau_2(0, 0, 1), & \tau_{2,2} &= \tau_2(0, 0, 1), \end{aligned}$$

→  $F^1 = \tau_1 d\theta_1,$   
 $F^2 = \tau_2(d\theta_2 - d\theta_1).$

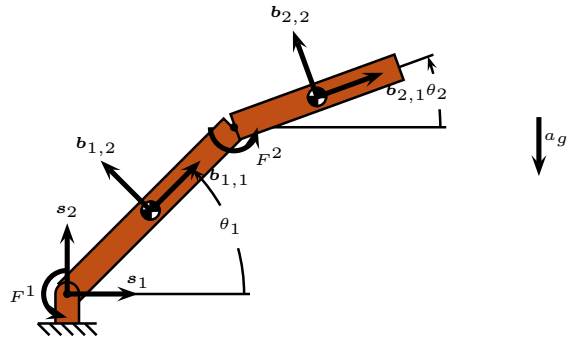

Gravitational force and equations of motion easily computed. •

**Forces (cont'd)**

**Example 16** *Rolling disk:*

$$\begin{aligned} \tau_{1,1} &= \tau_1(0, 0, 1), \\ \tau_{2,1} &= \tau_2(-\sin \theta, \cos \theta, 0), \end{aligned}$$

→  $F^1 = \tau_1 d\theta, \quad F^2 = \tau_2 d\phi.$

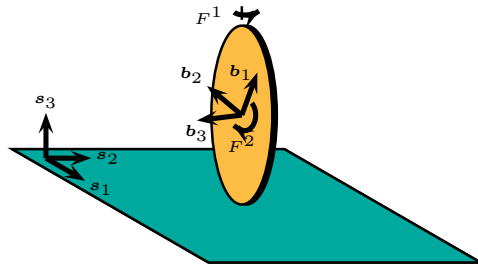

Equations of motion cannot be computed yet, because we have not dealt with... nonholonomic constraints. •

## Distributions and codistributions

- A **distribution** (smoothly) assigns to each point  $q \in Q$  a subspace  $\mathcal{D}_q$  of  $T_qQ$ .
- A **codistribution** (smoothly) assigns to each point  $q \in Q$  a subspace  $\Lambda_q$  of  $T_q^*Q$ .
- We shall always consider the case where the function  $q \mapsto \dim(\mathcal{D}_q)$  (resp.  $q \mapsto \dim(\Lambda_q)$ ) is constant, although there are important cases where this does not hold.
- Given a distribution  $\mathcal{D}$ , define a codistribution  $\text{ann}(\mathcal{D})$  by  $\text{ann}(\mathcal{D})_q = \{ \alpha_q \mid \alpha_q(v_q) = 0 \text{ for all } v_q \in \mathcal{D}_q \}$ .
- Given a codistribution  $\Lambda$ , define a distribution  $\text{coann}(\Lambda)$  by  $\text{coann}(\Lambda)_q = \{ v_q \mid \alpha_q(v_q) = 0 \text{ for all } \alpha_q \in \Lambda_q \}$ .

## Nonholonomic constraints

- An interconnected mechanical system with configuration manifold  $Q$ , kinetic energy metric  $\mathbb{G}$  and external force  $F$ .
- A **nonholonomic constraint** restricts the set of admissible velocities at each point  $q$  to lie in a subspace  $\mathcal{D}_q$ , i.e., it is defined by a distribution  $\mathcal{D}$ .

**Example 17** At a configuration  $q$  with coordinates  $(x, y, \theta, \phi)$ , the admissible velocities satisfy

$$\dot{x} = \rho \dot{\phi} \cos \theta$$

$$\dot{y} = \rho \dot{\phi} \sin \theta.$$

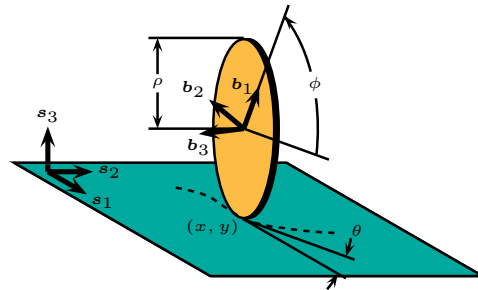

Thus  $\mathcal{D}_q$  has  $\{X_1(q), X_2(q)\}$  as basis, where

$$X_1 = \rho \cos \theta \frac{\partial}{\partial x} + \rho \sin \theta \frac{\partial}{\partial y} + \frac{\partial}{\partial \phi}, \quad X_2 = \frac{\partial}{\partial \theta}.$$

### Nonholonomic constraints (cont'd)

- *Question:* What are the equations of motion for a system with nonholonomic constraints?
- *Answer:* Determined by the **Lagrange–d'Alembert Principle**.
- We will skip a lot of physics and metaphysics, and go right to the affine connection formulation, originally due to Synge [1928].

### Nonholonomic constraints (cont'd)

- Let  $\mathcal{D}^\perp$  be the  $\mathbb{G}$ -orthogonal complement to  $\mathcal{D}$ , let  $P_{\mathcal{D}}$  be the  $\mathbb{G}$ -orthogonal projection onto  $\mathcal{D}$ , and let  $P_{\mathcal{D}^\perp}$  be the  $\mathbb{G}$ -orthogonal projection onto  $\mathcal{D}^\perp$ .
- Define an affine connection  $\overset{\mathcal{D}}{\nabla}$  by

$$\overset{\mathcal{D}}{\nabla}_X Y = \overset{\mathbb{G}}{\nabla}_X Y + (\overset{\mathbb{G}}{\nabla}_X P_{\mathcal{D}^\perp})(Y).$$

**(Not obvious) Theorem 18** *The following are equivalent:*

- (i)  $t \mapsto \gamma(t)$  is a trajectory for the system subject to the external force  $F$ ;
- (ii)  $\overset{\mathcal{D}}{\nabla}_{\gamma'(t)} \gamma'(t) = P_{\mathcal{D}}(\overset{\mathbb{G}}{\nabla}^\sharp(F)(t, \gamma'(t)))$ .

### Affine connection control systems

- *Control force assumption:* Directions in which control forces are applied depend only on position, and not on time or velocity.
  - ➔ There exists covector fields  $F^1, \dots, F^m$  such that the control force takes the form  $F_{\text{con}} = \sum_{a=1}^m u^a F^a$ .
- Control forces appear in equations of motion after application of  $\mathbb{G}^\#$  and (possibly) projection by  $P_{\mathcal{D}}$ .
  - ➔ Model effects of input forces by vector fields  $Y_1, \dots, Y_m$ .
  - ➔ Model uncontrolled external forces by vector force  $Y$ .
- Nothing to be gained by assuming that affine connection comes from physics.
  - ➔ Use arbitrary affine connection  $\nabla$ .
- ➔ Control equations:

$$\nabla_{\gamma'(t)} \gamma'(t) = \sum_{a=1}^m u^a(t) Y_a(\gamma(t)) + Y(t, \gamma'(t)),$$

### Affine connection control systems (cont'd)

**Definition 19** A **forced affine connection control system** is a 6-tuple  $\Sigma = (\mathbb{Q}, \nabla, \mathcal{D}, Y, \mathcal{Y} = \{Y_1, \dots, Y_m\}, U)$  where

- (i)  $\mathbb{Q}$  is a manifold,
- (ii)  $\nabla$  is an affine connection such that  $\nabla_X Y$  takes values in  $\mathcal{D}$  if  $Y$  takes values in  $\mathcal{D}$ ,
- (iii)  $\mathcal{D}$  is a distribution,
- (iv)  $Y$  is a vector force taking values in  $\mathcal{D}$ ,
- (v)  $Y_1, \dots, Y_m$  are  $\mathcal{D}$ -valued vector fields, and
- (vi) and  $U \subset \mathbb{R}^m$ .

Take away “forced” if  $Y = 0$ . •

## Affine connection control systems (cont'd)

**Definition 20** A **control-affine system** is a triple  $\Sigma = (M, \mathcal{C} = \{f_0, f_1, \dots, f_m\}, U)$  where

- (i)  $M$  is a manifold,
- (ii)  $f_0, f_1, \dots, f_m$  are vector fields on  $M$ , and
- (iii)  $U \subset \mathbb{R}^m$ .

- Control equations:

$$\gamma'(t) = \underbrace{f_0(\gamma(t))}_{\substack{\text{drift} \\ \text{vector} \\ \text{field}}} + \sum_{a=1}^m u^a(t) \underbrace{f_a(\gamma(t))}_{\substack{\text{control} \\ \text{vector} \\ \text{field}}}.$$

## Affine connection control systems (cont'd)

- Affine connection control systems are control-affine systems.
  1. The state manifold is  $M = TQ$ .
  2. The drift vector field is denoted by  $S$  and called the **geodesic spray**.  
Coordinate expression:

$$f_0 = S = v^i \frac{\partial}{\partial q^i} - \Gamma_{jk}^i v^j v^k \frac{\partial}{\partial v^i} \quad \left( \text{cf. } \ddot{q}^i + \Gamma_{jk}^i \dot{q}^j \dot{q}^k = 0 \right).$$

3. The control vector fields are the **vertical lifts**  $\text{vlft}(Y_a)$  of the vector fields  $Y_a$ ,  $a \in \{1, \dots, m\}$ . Coordinate expression:

$$f_a = \text{vlft}(Y_a) = Y_a^i \frac{\partial}{\partial v^i}.$$

- Can add external force to drift to accommodate forced affine connection control systems.

## Representations of control equations

- **Global representation:**

$$\nabla_{\gamma'(t)} \gamma'(t) = \sum_{a=1}^m u^a(t) Y_a(\gamma(t)) + Y(t, \gamma'(t)).$$

- **Natural local representation:**

$$\ddot{q}^i + \Gamma_{jk}^i \dot{q}^j \dot{q}^k = \sum_{a=1}^m u^a Y_a^i + Y^i, \quad i \in \{1, \dots, m\}.$$

## Representations of control equations (cont'd)

- **Global first-order representation:**

$$\Upsilon'(t) = S(\Upsilon(t)) + \text{vft}(Y)(t, \Upsilon(t)) + \sum_{a=1}^m u^a(t) \text{vft}(Y_a)(\Upsilon(t)).$$

- **Natural first-order local representation:**

$$\dot{q}^i = v^i, \quad i \in \{1, \dots, n\},$$

$$\dot{v}^i = -\Gamma_{jk}^i v^j v^k + Y^i + \sum_{a=1}^m u^a Y_a^i, \quad i \in \{1, \dots, n\}.$$

### Representations of control equations (cont'd)

- Let  $\mathcal{X} = \{X_1, \dots, X_n\}$  be vector fields defined on a chart domain  $\mathcal{U}$  with the property that, for each  $q \in \mathcal{U}$ ,  $\{X_1(q), \dots, X_n(q)\}$  is a basis for  $T_q\mathbb{Q}$ .
- For  $q \in \mathcal{U}$  and  $w_q \in T_q\mathbb{Q}$ , write  $w_q = v^i X_i(q)$ ;  $\{v^1, \dots, v^n\}$  are **pseudo-velocities**.
- The **generalized Christoffel symbols** are

$$\nabla_{X_j} X_k = \tilde{\Gamma}_{jk}^i X_i, \quad j, k \in \{1, \dots, n\}.$$

- **Poincaré local representation:**

$$\begin{aligned} \dot{q}^i &= X_j^i v^j, & i \in \{1, \dots, n\}, \\ \dot{v}^i &= -\tilde{\Gamma}_{jk}^i v^j v^k - \tilde{Y}^i + \sum_{a=1}^m u^a \tilde{Y}_a^i, & i \in \{1, \dots, n\}, \end{aligned}$$

where  $\tilde{\cdot}$  means components with respect to the basis  $\mathcal{X}$ .

### Representations of control equations (cont'd)

- In the case when  $\nabla = \overset{\mathbb{D}}{\nabla}$ , this simplifies when we choose  $\{X_1, \dots, X_n\}$  such that  $\{X_1(q), \dots, X_k(q)\}$  forms a  $\mathbb{G}$ -orthogonal basis for  $\mathcal{D}_q$ .  $\longrightarrow$

$$\tilde{\Gamma}_{\alpha\beta}^\delta(q) = \frac{1}{\|X_\delta(q)\|_{\mathbb{G}}^2} \mathbb{G}(\overset{\mathbb{G}}{\nabla}_{X_\alpha} X_\beta(q), X_\delta(q)), \quad \alpha, \beta, \delta \in \{1, \dots, k\}.$$

Significant advantages in symbolic computation.

- **orthogonal Poincaré representation:**

$$\begin{aligned} \dot{q}^i &= X_\alpha^i v^\alpha, & i \in \{1, \dots, n\}, \\ \dot{v}^\delta &= -\tilde{\Gamma}_{\alpha\beta}^\delta v^\alpha v^\beta + \frac{1}{\|X_\delta\|_{\mathbb{G}}^2} \left( \langle F; X_\delta \rangle + \sum_{a=1}^m u^a \langle F^a; X_\delta \rangle \right), & \delta \in \{1, \dots, k\}. \end{aligned}$$

### Representations of control equations (cont'd)

- Seems unspeakably ugly, but is easily automated in symbolic manipulation language.
- *Snakeboard* example.

## Controllability theory

1. Definitions of controllability and background for control-affine systems
2. Accessibility theorem
3. Controllability definitions and theorems for ACCS
4. Good/bad conditions
5. Examples
6. Snakeboard using Mma
7. Series expansions

### Reachable sets for control-affine systems

- A control-affine system  $\Sigma = (M, \mathcal{C} = \{f_0, f_1, \dots, f_m\}, U)$
- A **controlled trajectory** of  $\Sigma$  is a pair  $(\gamma, u)$ , where  $u: I \rightarrow U$  is locally integrable, and  $\gamma: I \rightarrow M$  is the locally absolutely continuous

$$\gamma'(t) = f_0(\gamma(t)) + \sum_{a=1}^m u^a(t) f_a(\gamma(t))$$

- $\text{Ctraj}(\Sigma, T)$  is set of controlled trajectories  $(\gamma, u)$  for  $\Sigma$  defined on  $[0, T]$
- Define the various sets of points that can be reached by trajectories of a control-affine system. For  $x_0 \in M$ , the **reachable set** of  $\Sigma$  from  $x_0$  is

$$\mathcal{R}_\Sigma(x_0, T) = \{ \gamma(T) \mid (\gamma, u) \in \text{Ctraj}(\Sigma, T), \gamma(0) = x_0 \},$$

$$\mathcal{R}_\Sigma(x_0, \leq T) = \bigcup_{t \in [0, T]} \mathcal{R}_\Sigma(x_0, t).$$

### Controllability notions for control-affine systems

$\Sigma = (M, \mathcal{C} = \{f_0, f_1, \dots, f_m\}, U)$  is  $C^\infty$ -control-affine system,  $x_0 \in M$

- $\Sigma$  is **accessible** from  $x_0$  if there exists  $T > 0$  such that  $\text{int}(\mathcal{R}_\Sigma(x_0, \leq t)) \neq \emptyset$  for  $t \in ]0, T]$
- $\Sigma$  is **controllable** from  $x_0$  if, for each  $x \in M$ , there exists a  $T > 0$  and  $(\gamma, u) \in \text{Ctraj}(\Sigma, T)$  such that  $\gamma(0) = x_0$  and  $\gamma(T) = x$
- $\Sigma$  is **small-time locally controllable (STLC)** from  $x_0$  if there exists  $T > 0$  such that  $x_0 \in \text{int}(\mathcal{R}_\Sigma(x_0, \leq t))$  for each  $t \in ]0, T]$

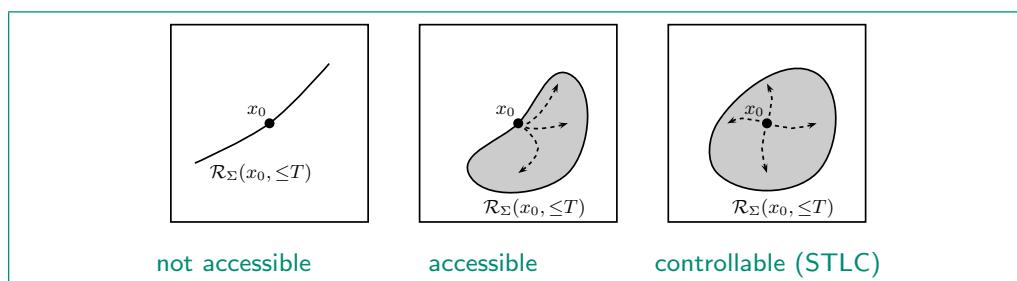

### Involutive closure

- $\mathcal{D}$  is a **smooth** distribution if it has smooth generators
- a distribution is **involutive** if it is closed under the operation of Lie bracket
- inductively define distributions  $\text{Lie}^{(l)}(\mathcal{D})$ ,  $l \in \{0, 1, 2, \dots\}$  by

$$\text{Lie}^{(0)}(\mathcal{D})_x = \mathcal{D}_x$$

$$\text{Lie}^{(l)}(\mathcal{D})_x = \text{Lie}^{(l-1)}(\mathcal{D})_x + \text{span}\{[X, Y](x) \mid$$

$$X \text{ takes values in } \text{Lie}^{(l_1)}(\mathcal{D})$$

$$Y \text{ takes values in } \text{Lie}^{(l_2)}(\mathcal{D}), \quad l_1 + l_2 = l - 1\}$$

- the **involutive closure**  $\text{Lie}^{(\infty)}(\mathcal{D})$  is the pointwise limit

**Theorem 21** (Under smoothness and regularity assumptions)  $\text{Lie}^{(\infty)}(\mathcal{D})$  contains  $\mathcal{D}$  and is contained in every involutive distribution containing  $\mathcal{D}$

### Accessibility results for control-affine systems

- $\Sigma = (M, \mathcal{C}, U)$  is an analytic control-affine system
- we say  $\Sigma$  satisfies the **Lie algebra rank condition (LARC)** at  $x_0$  if

$$\text{Lie}^{(\infty)}(\mathcal{C})_{x_0} = T_{x_0}M \quad \iff \quad \text{rank } \text{Lie}^{(\infty)}(\mathcal{C})_{x_0} = n$$

- a control set  $U$  is proper if  $\mathbf{0} \in \text{int}(\text{conv}(U))$

**Theorem 22** If  $U$  is proper, then

$\Sigma$  is accessible from  $x_0$  if and only if  $\Sigma$  satisfies LARC at  $x_0$

It is not known if there are useful necessary and sufficient conditions for STLC. Available results include a sufficient condition given as the “neutralization of bad bracket by good brackets of lower order”

## Examples of accessible control-affine systems

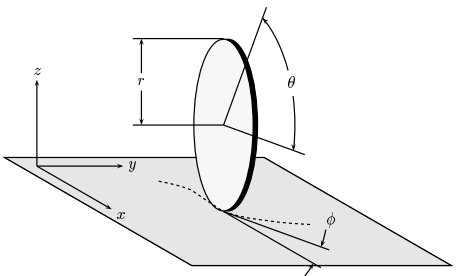

$$\begin{bmatrix} \dot{x} \\ \dot{y} \\ \dot{\phi} \\ \dot{\theta} \end{bmatrix} = \begin{bmatrix} \rho \cos \phi \\ \rho \sin \phi \\ 0 \\ 1 \end{bmatrix} u_1 + \begin{bmatrix} 0 \\ 0 \\ 1 \\ 0 \end{bmatrix} u_2$$

(unicycle dynamics, simplest wheeled robot dynamics)

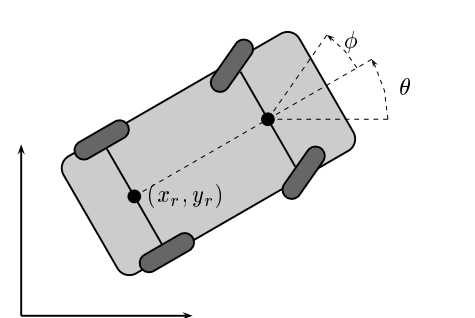

$$\begin{bmatrix} \dot{x}_r \\ \dot{y}_r \\ \dot{\theta} \\ \dot{\phi} \end{bmatrix} = \begin{bmatrix} \cos \theta \\ \sin \theta \\ \frac{1}{\ell} \tan \phi \\ 0 \end{bmatrix} u_1 + \begin{bmatrix} 0 \\ 0 \\ 0 \\ 1 \end{bmatrix} u_2$$

## Summary

- notions of accessibility and STLC
- tool: Lie bracket and involutive closure
- necessary and sufficient conditions for configuration accessibility

## Trajectories and reachable sets of mechanical systems

- (time-independent) general simple mechanical control system

$$\Sigma = (\mathbb{Q}, \mathbb{G}, V, F, \mathcal{D}, \mathcal{F} = \{F^1, \dots, F^m\}, U)$$

- a **controlled trajectory** for  $\Sigma$  is pair  $(\gamma, u)$ , with  $u: I \rightarrow U$  and  $\gamma: I \rightarrow \mathbb{Q}$ , satisfying  $\gamma'(t_0) \in \mathcal{D}_{\gamma(t_0)}$  for some  $t_0 \in I$  and

$$\begin{aligned} \frac{\mathcal{D}}{\nabla} \gamma'(t) \gamma'(t) &= -P_{\mathcal{D}}(\text{grad } V(\gamma(t))) + P_{\mathcal{D}}(\mathbb{G}^{\sharp}(F(\gamma'(t)))) \\ &\quad + \sum_{a=1}^m u^a(t) P_{\mathcal{D}}(\mathbb{G}^{\sharp}(F^a(\gamma(t)))). \end{aligned}$$

- $\text{Ctraj}(\Sigma, T)$  is set of  $[0, T]$ -**controlled trajectories** for  $\Sigma$  on  $\mathbb{Q}$
- **reachable sets** from states with *zero velocity*:

$$\mathcal{R}_{\Sigma, \tau\mathbb{Q}}(q_0, T) = \{ \gamma'(T) \mid (\gamma, u) \in \text{Ctraj}(\Sigma, T), \gamma'(0) = 0_{q_0} \},$$

$$\mathcal{R}_{\Sigma, \mathbb{Q}}(q_0, T) = \{ \gamma(T) \mid (\gamma, u) \in \text{Ctraj}(\Sigma, T), \gamma'(0) = 0_{q_0} \},$$

$$\mathcal{R}_{\Sigma, \tau\mathbb{Q}}(q_0, \leq T) = \bigcup_{t \in [0, T]} \mathcal{R}_{\Sigma, \tau\mathbb{Q}}(q_0, t), \quad \mathcal{R}_{\Sigma, \mathbb{Q}}(q_0, \leq T) = \bigcup_{t \in [0, T]} \mathcal{R}_{\Sigma, \mathbb{Q}}(q_0, t).$$

## Controllability notions for mechanical systems

$\Sigma = (\mathbb{Q}, \mathbb{G}, V, F, \mathcal{D}, \mathcal{F}, U)$  is general simple mechanical control system with  $F$  time-independent,  $U$  proper, and  $q_0 \in \mathbb{Q}$

- $\Sigma$  is **accessible** from  $q_0$  if there exists  $T > 0$  such that  $\text{int}_{\mathcal{D}}(\mathcal{R}_{\Sigma, \tau\mathbb{Q}}(q_0, \leq t)) \neq \emptyset$  for  $t \in ]0, T]$
- $\Sigma$  is **configuration accessible** from  $q_0$  if there exists  $T > 0$  such that  $\text{int}(\mathcal{R}_{\Sigma, \mathbb{Q}}(q_0, \leq t)) \neq \emptyset$  for  $t \in ]0, T]$
- $\Sigma$  is **small-time locally controllable (STLC)** from  $q_0$  if there exists  $T > 0$  such that  $0_{q_0} \in \text{int}_{\mathcal{D}}(\mathcal{R}_{\Sigma, \tau\mathbb{Q}}(q_0, \leq t))$  for  $t \in ]0, T]$ .
- $\Sigma$  is **small-time locally configuration controllable (STLCC)** from  $q_0$  if there exists  $T > 0$  such that  $q_0 \in \text{int}(\mathcal{R}_{\Sigma, \mathbb{Q}}(q_0, \leq t))$  for  $t \in ]0, T]$ .

### Controllability for mechanical systems: linearization results

- Let  $\Sigma = (\mathbb{R}^n, \mathbf{M}, \mathbf{K}, \mathbf{F})$  be a linear mechanical control system, i.e.,  $\mathbf{M}$  and  $\mathbf{K}$  are square  $n \times n$  matrices and  $\mathbf{F}$  is  $n \times m$ ,

$$\mathbf{M}\ddot{x}(t) + \mathbf{K}x(t) = \mathbf{F}u(t)$$

**Theorem 23** *The following two statements are equivalent:*

- $\Sigma$  is STLC from  $0 \oplus 0$
- the following matrix has maximal rank

$$\left[ \mathbf{M}^{-1}\mathbf{F} \mid \mathbf{M}^{-1}\mathbf{K} \cdot (\mathbf{M}^{-1}\mathbf{F}) \mid \dots \mid (\mathbf{M}^{-1}\mathbf{K})^{n-1} \cdot (\mathbf{M}^{-1}\mathbf{F}) \right]$$

- Corresponding linearization result where, in coordinates,  $\mathbf{M} = \mathbb{G}(q_0)$ ,  $\mathbf{K} = \text{Hess } V(q_0)$ , and no dissipation

**Corollary 24** *If  $\Sigma = (\mathbb{Q}, \mathbb{G}, V = 0, \mathcal{F}, U)$  is underactuated at  $q_0$ , then its linearization about  $0_{q_0}$  is not accessible from the origin.*

### The symmetric product

- given manifold  $\mathbb{Q}$  with affine connection  $\nabla$
- the **symmetric product** corresponding to  $\nabla$  is the operation that assigns to vector fields  $X$  and  $Y$  on  $\mathbb{Q}$  the vector field

$$\langle X : Y \rangle = \nabla_X Y + \nabla_Y X$$

- In coordinates

$$\langle X : Y \rangle^k = \frac{\partial Y^k}{\partial q^i} X^i + \frac{\partial X^k}{\partial q^i} Y^i + \Gamma_{ij}^k (X^i Y^j + X^j Y^i)$$

### Symmetric product as a Lie bracket

- Given vector field  $Y$  on  $Q$ , its **vertical lift**  $\text{vlft}(Y)$  is vector field on  $TQ$

$$Y = Y^i \frac{\partial}{\partial q^i} \approx \begin{bmatrix} Y^1 \\ \vdots \\ Y^n \end{bmatrix}, \quad \text{vlft}(Y) = Y^i \frac{\partial}{\partial v^i} \approx \begin{bmatrix} 0 \\ Y \end{bmatrix} = 0 \oplus Y$$

- Recall: The drift vector field  $S$  and called the **geodesic spray**:

$$S = v^i \frac{\partial}{\partial q^i} - \Gamma_{jk}^i v^j v^k \frac{\partial}{\partial v^i}$$

- remarkable Lie bracket identities:

$$\begin{aligned} [S, \text{vlft}(Y)](0_q) &= -Y(q) \oplus 0_q \\ [\text{vlft}(Y_a), [S, \text{vlft}(Y_b)]](v_q) &= \text{vlft}(\langle Y_a : Y_b \rangle)(v_q) \end{aligned}$$

### Symmetric closure

- take smooth input distribution  $\mathcal{Y}$
- a distribution is **geodesically invariant** if it is closed under the operation of symmetric product
- inductively define distributions  $\text{Sym}^{(l)}(\mathcal{Y})$ ,  $l \in \{0, 1, 2, \dots\}$  by

$$\text{Sym}^{(0)}(\mathcal{Y})_q = \mathcal{Y}_q$$

$$\text{Sym}^{(l)}(\mathcal{Y})_q = \text{Sym}^{(l-1)}(\mathcal{Y})_q + \text{span}\{\langle X : Y \rangle(q) \mid$$

$$X \text{ takes values in } \text{Sym}^{(l_1)}(\mathcal{Y}), Y \text{ takes values in } \text{Sym}^{(l_2)}(\mathcal{Y}), l_1 + l_2 = l - 1\}$$

- the **symmetric closure**  $\text{Sym}^{(\infty)}(\mathcal{Y})$  is the pointwise limit

**Theorem 25** (Under smoothness and regularity assumptions)  $\text{Sym}^{(\infty)}(\mathcal{Y})$  contains  $\mathcal{Y}$  and is contained in every geodesically invariant distribution containing  $\mathcal{Y}$

### Accessibility results for mechanical systems

- $\Sigma = (\mathbf{Q}, \nabla, \mathcal{D}, \mathcal{Y} = \{Y_1, \dots, Y_m\}, U)$  is an analytic ACCS
- $U$  proper
- $q_0$  point in  $\mathbf{Q}$

**Theorem 26** 1.  $\Sigma$  is accessible from  $q_0$  if and only if

$$\text{Sym}^{(\infty)}(\mathcal{Y})_{q_0} = \mathcal{D}_{q_0} \text{ and } \text{Lie}^{(\infty)}(\mathcal{D})_{q_0} = \mathbb{T}_{q_0} \mathbf{Q}$$

2.  $\Sigma$  is configuration accessible from  $q_0$  if and only if

$$\text{Lie}^{(\infty)}(\text{Sym}^{(\infty)}(\mathcal{Y}))_{q_0} = \mathbb{T}_{q_0} \mathbf{Q}$$

*Key result in proof:* If  $\mathcal{C}_\Sigma = \{S, \text{vft}(Y_1), \dots, \text{vft}(Y_m)\}$ , then, for  $q_0 \in \mathbf{Q}$ ,

$$\text{Lie}^{(\infty)}(\mathcal{C}_\Sigma)_{0_{q_0}} \simeq \text{Lie}^{(\infty)}(\text{Sym}^{(\infty)}(\mathcal{Y}))_{q_0} \oplus \text{Sym}^{(\infty)}(\mathcal{Y})_{q_0}$$

### Notions for sufficient test

Consider iterated symmetric products in the vector fields  $\{Y_1, \dots, Y_m\}$ :

1. A symmetric product is **bad** if it contains an even number of each of the vector fields  $Y_1, \dots, Y_m$ , and otherwise is **good**.  
E.g.,  $\langle\langle Y_a : Y_b \rangle\rangle$  is bad,  $\langle Y_a : \langle Y_b : Y_c \rangle \rangle$  is good
2. The **degree** of a symmetric product is the total number of input vector fields comprising the symmetric product.  
E.g.,  $\langle\langle Y_a : Y_b \rangle\rangle$  has degree 4
3. If  $P$  is a symmetric product and if  $\sigma$  is a permutation on  $\{1, \dots, m\}$ , define  $\sigma(P)$  as symmetric product where each  $Y_a$  is replaced with  $Y_{\sigma(a)}$

### Controllability mechanisms

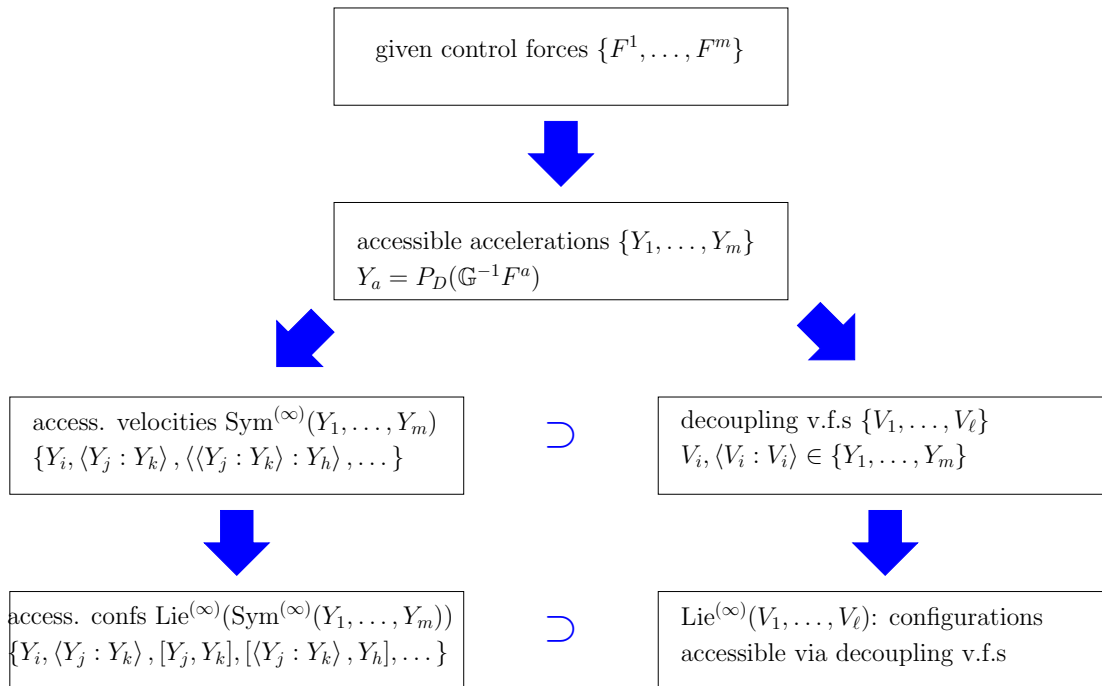

### Controllability for ACCS

- ACCS  $\Sigma = (Q, \nabla, \mathcal{D}, \mathcal{Y}, U)$ ,  $q_0 \in Q$ ,  $U$  proper
- $\Sigma$  satisfies **bad vs good condition** if for every bad symmetric product  $P$

$$\sum_{\sigma \in S_m} \sigma(P)(q_0) \in \text{span}_{\mathbb{R}} \{P_1(q_0), \dots, P_k(q_0)\}$$

where  $P_1, \dots, P_k$  are good symmetric products of degree less than  $P$

#### Theorem 27

rank  $\text{Sym}^{(\infty)}(\mathcal{Y})_{q_0}$  is maximal  
bad vs good



**STLC= small-time locally controllable**

$(q_0, 0) \xrightarrow{u} (q_f, v_f)$  can reach open set of configurations and velocities

rank  $\text{Lie}^{(\infty)}(\text{Sym}^{(\infty)}(\mathcal{Y}))_{q_0} = n$   
bad vs good



**STLCC= small-time locally configuration controllable**

$(q_0, 0) \xrightarrow{u} (q_f, v_f)$  can reach open set of configurations

### Summary for control-affine systems

- notions of accessibility and STLC
- tool: Lie bracket and involutive closure
- necessary and sufficient conditions for accessibility

### Summary for ACCS

- notions of configuration accessibility and STLCC
- tool: symmetric product and symmetric closure
- necessary and sufficient conditions for accessibility

### Controllability examples

- $Y_1$  is internal torque and  $Y_2$  is extension force.
  - *Both inputs*: not accessible, configuration accessible, and STLCC (satisfies sufficient condition).
  - $Y_1$  *only*: configuration accessible but not STLCC.
  - $Y_2$  *only*: not configuration accessible.

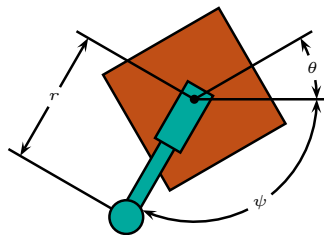

- $Y_1$  is component of force along center axis, and  $Y_2$  is component of force perpendicular to center axis.

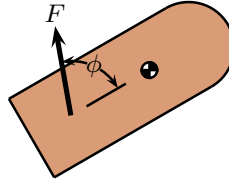

- $Y_1$  and  $Y_2$ : accessible and STLCC (satisfies sufficient condition).
- $Y_1$  and  $Y_3$ : accessible and STLCC (satisfies sufficient condition).
- $Y_1$  only or  $Y_3$  only: not configuration accessible.
- $Y_2$  only: accessible but not STLCC.
- $Y_2$  and  $Y_3$ : configuration accessible and STLCC (but fails sufficient condition).

- $Y_1$  is “rolling” input and  $Y_2$  is “spinning” input.

- $Y_1$  and  $Y_2$ : configuration accessible and STLCC (satisfies sufficient condition).
- $Y_1$  only: not configuration accessible.
- $Y_2$  only: not configuration accessible.

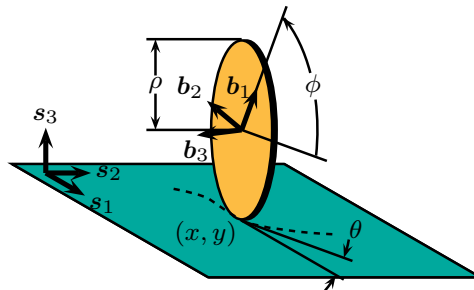

- $Y_1$  rotates wheels and  $Y_2$  rotates rotor.
  - $Y_1$  and  $Y_2$ : configuration accessible and STLCC (satisfies sufficient condition).
  - $Y_1$  only: not configuration accessible.
  - $Y_2$  only: not configuration accessible.

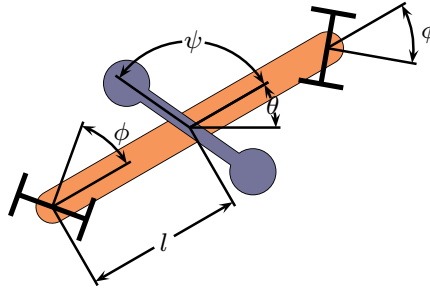

- Single input at joint.
- Configuration accessible, but not STLCC.

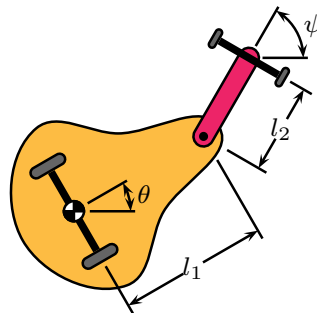

### Series expansion for affine connection control systems

$\Sigma = (Q, \nabla, \mathcal{D}, \mathcal{Y} = \{Y_1, \dots, Y_m\}, U)$  is an analytic ACCS

$$\begin{aligned} \nabla_{\gamma'(t)} \gamma'(t) &= Y(t, \gamma(t)) \\ \gamma'(0) &= 0 \end{aligned}$$



$$\begin{aligned} \gamma'(t) &= \sum_{k=1}^{+\infty} V_k(t, \gamma(t)) && \text{absolute, uniform convergence} \\ V_1(t, q) &= \int_0^t Y(s, q) ds \\ V_k(t, q) &= -\frac{1}{2} \sum_{j=1}^{k-1} \int_0^t \langle V_j(s, q) : V_{k-j}(s, q) \rangle ds \end{aligned}$$

**Series: comments**  $\gamma'(t) = \sum_{k=1}^{+\infty} V_k(t, \gamma(t))$

$$\begin{cases} V_1(t, q) &= \int_0^t Y(s, q) ds \\ V_{k+1}(t, q) &= -\frac{1}{2} \sum_{j=1}^k \int_0^t \langle V_j(s, q) : V_{k-j}(s, q) \rangle ds \end{cases}$$

**Error bounds:**

$$\|V_k\| = O(\|Y\|^k t^{2k-1})$$

**In abbreviated notation**

$$V_1 = \bar{Y}, \quad V_2 = -\frac{1}{2} \overline{\langle \bar{Y} : \bar{Y} \rangle}, \quad V_3 = \frac{1}{2} \overline{\langle \overline{\langle \bar{Y} : \bar{Y} \rangle} : \bar{Y} \rangle}$$

so that

$$\gamma'(t) = \bar{Y}(t, \gamma(t)) - \frac{1}{2} \overline{\langle \bar{Y} : \bar{Y} \rangle}(t, \gamma(t)) + \frac{1}{2} \overline{\langle \overline{\langle \bar{Y} : \bar{Y} \rangle} : \bar{Y} \rangle}(t, \gamma(t)) + O(\|Y\|^4 t^7)$$

## Kinematic reductions and motion planning

1. Motion planning problems for driftless systems and ACCS
2. How to reduce the MPP for ACCS to the MPP for a driftless system
3. Kinematic reductions: notion, theorems and examples
4. Kinematic controllability
5. Inverse kinematics and example solutions
6. Motion planning problems with animations

### Motion planning for driftless systems

- $(M, \{X_1, \dots, X_m\}, U)$  is driftless system:

$$\gamma'(t) = \sum_{a=1}^m X_a(\gamma(t))u^a(t)$$

where  $u$  are  $U$ -valued integrable inputs — let  $\mathcal{U}$  be a set of inputs

- **$\mathcal{U}$ -motion planning problem** is:

Given  $x_0, x_1 \in M$ , find  $u \in \mathcal{U}$ , defined on some interval  $[0, T]$ , so that the controlled trajectory  $(\gamma, u)$  with  $\gamma(0) = x_0$  satisfies  $\gamma(T) = x_1$

## Motion planning for driftless systems: cont'd

- Examples of  $\mathcal{U}$ -motion planning problem

1. **motion planning problem with continuous inputs**

2. **motion planning problem using primitives:**

$$U = \{e_1, \dots, e_m, -e_1, \dots, -e_m\}$$

$\mathcal{U}$  is collection of piecewise constant  $U$ -valued functions

Then,  $\gamma$  is concatenation of integral curves, possibly running backwards in time, of the vector fields  $X_1, \dots, X_m$ . Each curves is a **primitive**

- **Motion planning using primitives** Consider  $(M, \{X_1, \dots, X_m\}, \mathbb{R}^m)$ . If  $\text{Lie}^{(\infty)}(\mathcal{X}) = \text{TM}$ , then, for each  $x_0, x_1 \in M$ , there exist  $k \in \mathbb{N}$ ,  $t_1, \dots, t_k \in \mathbb{R}$ , and  $a_1, \dots, a_k \in \{1, \dots, m\}$  such that

$$x_1 = \Phi_{t_k}^{X_{a_k}} \circ \dots \circ \Phi_{t_1}^{X_{a_1}}(x_0)$$

Technical conditions: smoothness, complete vector fields,  $M$  connected

## Motion planning for ACCS

- $(Q, \nabla, \mathcal{D}, \{Y_1, \dots, Y_m\}, U)$  is affine connection control system (ACCS)

$$\nabla_{\gamma'(t)} \gamma'(t) = \sum_{a=1}^m u^a(t) Y_a(\gamma(t))$$

- $\mathcal{U}$  is set of  $U$ -valued integrable inputs
- **$\mathcal{U}$ -motion planning problem** is:

Given  $q_0, q_1 \in Q$ , find  $u \in \mathcal{U}$ , defined on some interval  $[0, T]$ , so that the controlled trajectory  $(\gamma, u)$  with  $\gamma'(0) = 0_{q_0}$  has the property that  $\gamma'(T) = 0_{q_1}$

## How to reduce the MPP for ACCS to the MPP for a driftless system

Key idea: Kinematic Reductions

Goal: (low-complexity) kinematic representations for mechanical control systems

Consider an ACCS, i.e., systems with no potential energy, no dissipation

1. *ACCS model* with accelerations as control inputs mechanical systems:

$$\nabla_{\gamma'(t)} \gamma'(t) = \sum_{a=1}^m Y_a(\gamma(t)) u_a(t) \quad \mathcal{Y} = \text{span} \{Y_1, \dots, Y_m\}$$

2. *driftless = kinematic model* with velocities as control inputs

$$\gamma'(t) = \sum_{b=1}^{\ell} V_b(\gamma(t)) w_b(t) \quad \mathcal{V} = \text{span} \{V_1, \dots, V_{\ell}\}$$

$\ell$  is the rank of the reduction

## When can a second order system follow the solution of a first order?

ex:

Can follow any straight line and can turn  
2 preferred velocity fields  
(plus, configuration controllability)

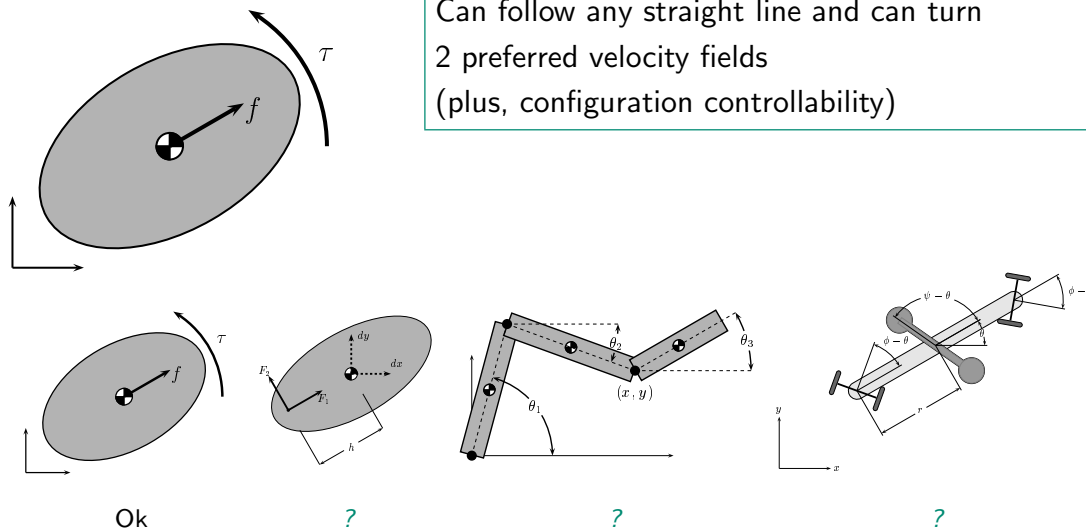

**Kinematic reductions**  $\mathcal{V} = \text{span}\{V_1, \dots, V_\ell\}$  is a **kinematic reduction** if any curve  $q: I \rightarrow Q$  solving the (controlled) kinematic model can be lifted to a solution of the (controlled) dynamic model.

rank 1 reductions are called **decoupling vector fields**

**Theorem 28** *The kinematic model induced by  $\{V_1, \dots, V_\ell\}$  is a kinematic reduction of  $(Q, \nabla, \mathcal{D}, \{Y_1, \dots, Y_m\}, U)$  if and only if*

- (i)  $\mathcal{V} \subset \mathcal{Y}$
- (ii)  $\langle \mathcal{V} : \mathcal{V} \rangle \subset \mathcal{Y}$

### Examples of kinematic reductions

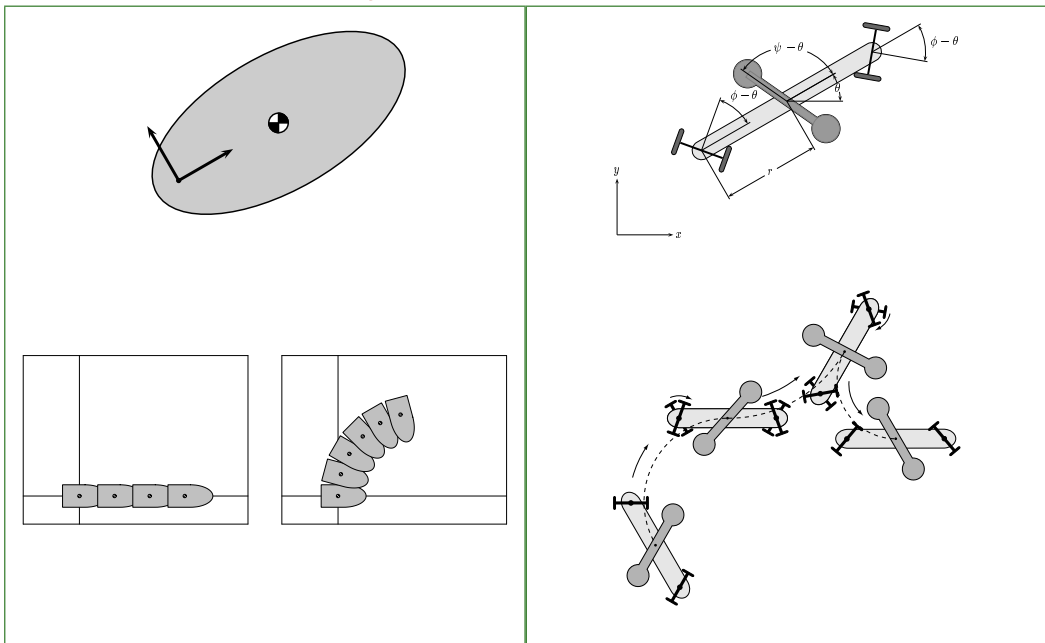

Two rank 1 kinematic reductions (decoupling vector fields)  
no rank 2 kinematic reductions

### Three link planar manipulator with passive link

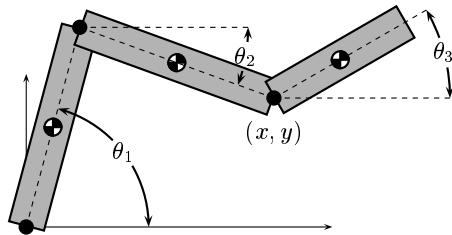

Actuator configuration	Decoupling vector fields	Kinematically controllable
(0,1,1)	2	yes
(1,0,1)	2	yes
(1,1,0)	2	yes

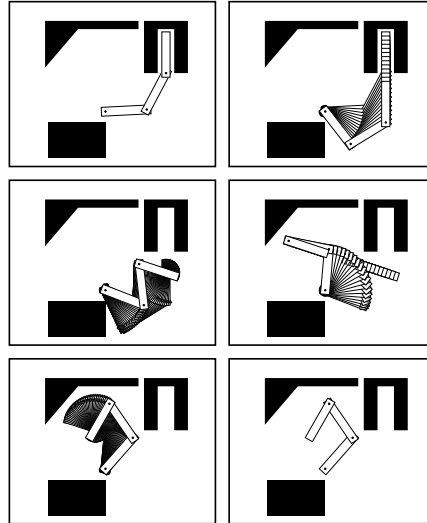

### When is a mechanical system kinematic?

When are all dynamic trajectories executable by a single kinematic model?

A dynamic model is *maximally reducible (MR)* if all its controlled trajectory (starting from rest) are controlled trajectory of a single kinematic reduction.

**Theorem 29**  $(Q, \nabla, \mathcal{D}, \{Y_1, \dots, Y_m\}, U)$  is maximally reducible if and only if

- (i) the kinematic reduction is the input distribution  $\mathcal{Y}$
- (ii)  $\langle \mathcal{Y} : \mathcal{Y} \rangle \subset \mathcal{Y}$

## Examples of maximally reducible systems

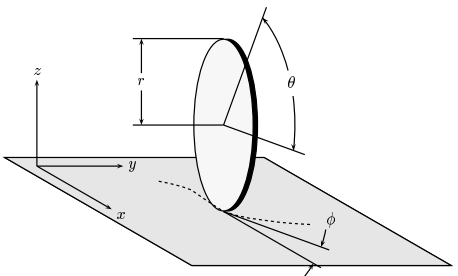

$$\begin{bmatrix} \dot{x} \\ \dot{y} \\ \dot{\phi} \\ \dot{\theta} \end{bmatrix} = \begin{bmatrix} \rho \cos \phi \\ \rho \sin \phi \\ 0 \\ 1 \end{bmatrix} v + \begin{bmatrix} 0 \\ 0 \\ 1 \\ 0 \end{bmatrix} \omega$$

(unicycle dynamics, simplest wheeled robot dynamics)

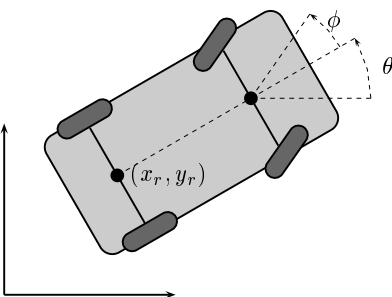

$$\begin{bmatrix} \dot{x}_r \\ \dot{y}_r \\ \dot{\theta} \\ \dot{\phi} \end{bmatrix} = \begin{bmatrix} \cos \theta \\ \sin \theta \\ \frac{1}{\ell} \tan \phi \\ 0 \end{bmatrix} v + \begin{bmatrix} 0 \\ 0 \\ 0 \\ 1 \end{bmatrix} \omega$$

## Kinematic controllability

**Objective:** controllability notions and tests for mechanical systems and reductions

Consider:  $(Q, \nabla, \mathcal{D}, \{Y_1, \dots, Y_m\}, U)$

$V_1, \dots, V_\ell$  decoupling v.f.s  
 $\text{rank Lie}^{(\infty)}(V_1, \dots, V_\ell) = n$



*KC= locally kinematically controllable*

$(q_0, 0) \xrightarrow{u} (q_f, 0)$  can reach open set of configurations by concatenating motions along kinematic reductions

$\text{rank Sym}^{(\infty)}(\mathcal{Y}) = n$ ,  
 "bad vs good"



*STLC= small-time locally controllable*

$(q_0, 0) \xrightarrow{u} (q_f, v_f)$  can reach open set of configurations and velocities

$\text{rank Lie}^{(\infty)}(\text{Sym}^{(\infty)}(\mathcal{Y})) = n$ ,  
 "bad vs good"



*STLCC= small-time locally configuration controllable*

$(q_0, 0) \xrightarrow{u} (q_f, v_f)$  can reach open set of configurations

## Controllability mechanisms

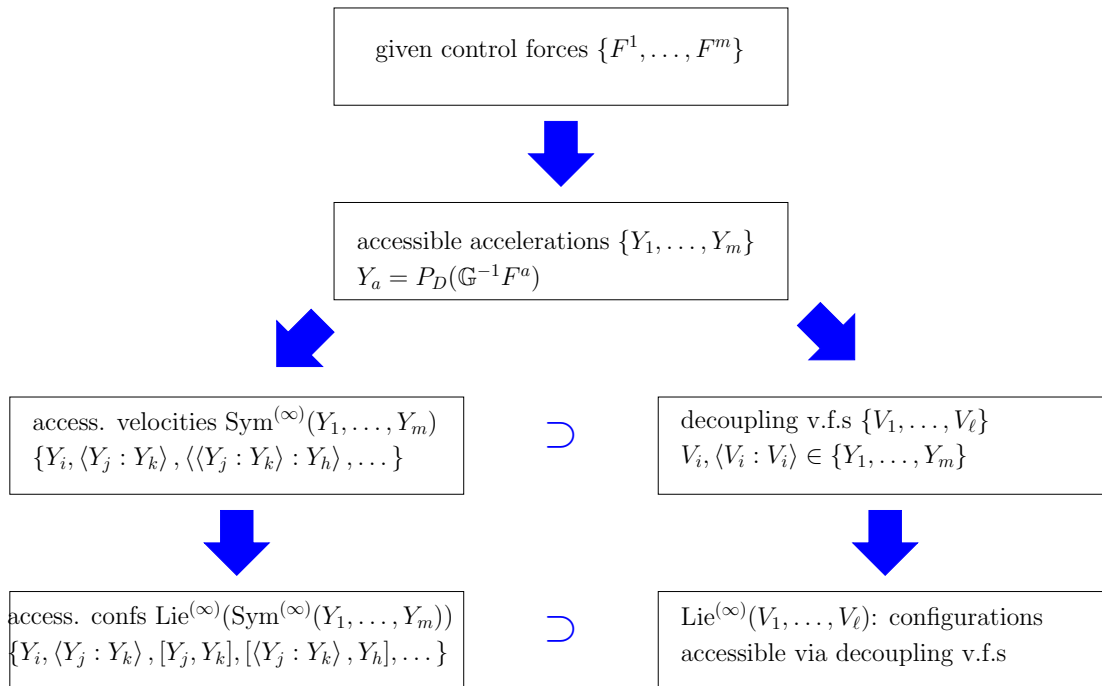

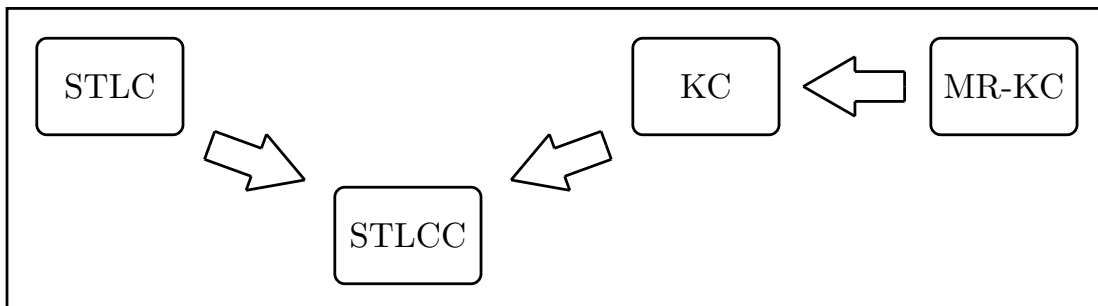

## Controllability inferences

- STLC = small-time locally controllable
- STLCC = small-time locally configuration controllable
- KC = locally kinematically controllable
- MR-KC = maximally reducible, locally kinematically controllable

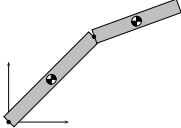
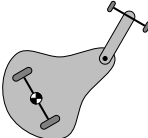
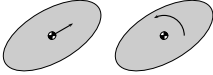

There exist counter-examples for each missing implication sign.

### Cataloging kinematic reductions and controllability of example systems

System	Picture	Reducibility	Controllability
planar 2R robot single torque at either joint: (1, 0), (0, 1) $n = 2, m = 1$		(1, 0): no reductions (0, 1): maximally reducible	accessible not accessible or STLCC
roller racer single torque at joint $n = 4, m = 1$		no kinematic reductions	accessible, not STLCC
planar body with single force or torque $n = 3, m = 1$		decoupling v.f.	reducible, not accessible
planar body with single generalized force $n = 3, m = 1$		no kinematic reductions	accessible, not STLCC
planar body with two forces $n = 3, m = 2$		two decoupling v.f.	KC, STLC

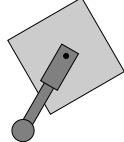
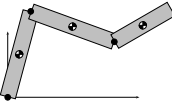
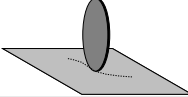
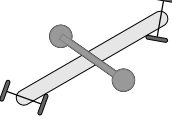
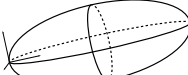
robotic leg $n = 3, m = 2$		two decoupling v.f., maximally reducible	KC
planar 3R robot, two torques: (0, 1, 1), (1, 0, 1), (1, 1, 0) $n = 3, m = 2$		(1, 0, 1) and (1, 1, 0): two decoupling v.f. (0, 1, 1): two decoupling v.f. and maximally reducible	(1, 0, 1) and (1, 1, 0): KC and STLC (0, 1, 1): KC
rolling penny $n = 4, m = 2$		fully reducible	KC
snakeboard $n = 5, m = 2$		two decoupling v.f.	KC, STLCC
3D vehicle with 3 generalized forces $n = 6, m = 3$		three decoupling v.f.	KC, STLC

## Summary

- relationship between trajectories of dynamic and of kinematic models of mechanical systems
- kinematic reductions (multiple, low rank), and maximally reducible systems
- controllability mechanisms, e.g., STLC vs kinematic controllability

## Trajectory design via inverse kinematics

Objective: find  $u$  such that  $(q_{\text{initial}}, 0) \xrightarrow{u} (q_{\text{target}}, 0)$

Assume:

1.  $(Q, \nabla, \mathcal{D}, \{Y_1, \dots, Y_m\}, U)$  is *kinematically controllable*
2.  $Q = G$  and decoupling v.f.s  $\{V_1, \dots, V_\ell\}$  are *left-invariant*

### Left invariant vector fields on matrix Lie groups

- Matrix Lie groups are manifolds of matrices closed under the operations of matrix multiplication and inversion
- Example:  $SO(3) = \{ \mathbf{R} \in \mathbb{R}^{3 \times 3} \mid \mathbf{R}\mathbf{R}^T = I_3, \det(\mathbf{R}) = +1 \}$
- left invariant vector fields have the following properties:
  1.  $\dot{\mathbf{R}}(t) = X_{\mathbf{V}}(\mathbf{R}(t)) = \mathbf{R}(t) \cdot \mathbf{V}$  for some matrix  $\mathbf{V}$  (linear dependence)
  2. flow of left invariant vector field is equal to left multiplication

$$\Phi_t^{X_{\mathbf{V}}}(\mathbf{R}_0) = \mathbf{R}_0 \cdot \exp(t\mathbf{V})$$

3.  $\exp(t\mathbf{V}) \in SO(3)$ , that is,  $\mathbf{V} \in \mathfrak{so}(3)$  set of skew symmetric matrices
4. For  $e_1, e_2, e_3$  the standard basis of  $\mathbb{R}^3$ ,

$$\hat{e}_1 = \begin{bmatrix} 0 & 0 & 0 \\ 0 & 0 & -1 \\ 0 & 1 & 0 \end{bmatrix}, \quad \hat{e}_2 = \begin{bmatrix} 0 & 0 & -1 \\ 0 & 0 & 0 \\ 1 & 0 & 0 \end{bmatrix}, \quad \hat{e}_3 = \begin{bmatrix} 0 & -1 & 0 \\ 1 & 0 & 0 \\ 0 & 0 & 0 \end{bmatrix}$$

### Trajectory design via inverse kinematics

**Objective:** find  $u$  such that  $(q_{\text{initial}}, 0) \xrightarrow{u} (q_{\text{target}}, 0)$

**Assume:**

1.  $(\mathbf{Q}, \nabla, \mathcal{D}, \{Y_1, \dots, Y_m\}, U)$  is *kinematically controllable*
2.  $\mathbf{Q} = \mathbf{G}$  and *decoupling v.f.s*  $\{V_1, \dots, V_\ell\}$  are *left-invariant*
  - $\implies$  matrix exponential  $\exp: \mathfrak{g} \rightarrow \mathbf{G}$  gives closed-form flow
  - $\implies$  composition of flows is matrix product

**Objective:** select a finite-length combination of  $k$  flows along  $\{V_1, \dots, V_\ell\}$  and coasting times  $\{t_1, \dots, t_k\}$  such that

$$q_{\text{initial}}^{-1} q_{\text{target}} = g_{\text{desired}} = \exp(t_1 V_{a_1}) \cdots \exp(t_k V_{a_k}).$$

No general methodology is available  $\implies$  catalog for relevant example systems  
 $SO(3), SE(2), SE(3)$ , etc

**Inverse-kinematic planner on  $SO(3)$**  Any underactuated controllable system on  $SO(3)$  is equivalent to

$$V_1 = e_z = (0, 0, 1) \quad V_2 = (a, b, c) \text{ with } a^2 + b^2 \neq 0$$

*Motion Algorithm:* given  $R \in SO(3)$ , flow along  $(e_z, V_2, e_z)$  for coasting times

$$t_1 = \text{atan2}(w_1 R_{13} + w_2 R_{23}, -w_2 R_{13} + w_1 R_{23}) \quad t_2 = \text{acos}\left(\frac{R_{33} - c^2}{1 - c^2}\right)$$

$$t_3 = \text{atan2}(v_1 R_{31} + v_2 R_{32}, v_2 R_{31} - v_1 R_{32})$$

where  $z = \begin{bmatrix} 1 - \cos t_2 \\ \sin t_2 \end{bmatrix}$ ,  $\begin{bmatrix} w_1 \\ w_2 \end{bmatrix} = \begin{bmatrix} ac & b \\ cb & -a \end{bmatrix} z$ ,  $\begin{bmatrix} v_1 \\ v_2 \end{bmatrix} = \begin{bmatrix} ac & -b \\ cb & a \end{bmatrix} z$

**Local Identity Map =**  $R \xrightarrow{\mathcal{JK}} (t_1, t_2, t_3) \xrightarrow{\mathcal{FK}} \exp(t_1 e_z) \exp(t_2 V_2) \exp(t_3 e_z)$

**Inverse-kinematic planner on  $SO(3)$ : simulation** The system can rotate about  $(0, 0, 1)$  and  $(a, b, c) = (0, 1, 1)$

Rotation from  $I_3$  onto target rotation  $\exp(\pi/3, \pi/3, 0)$

As time progresses, the body is translated along the inertial  $x$ -axis

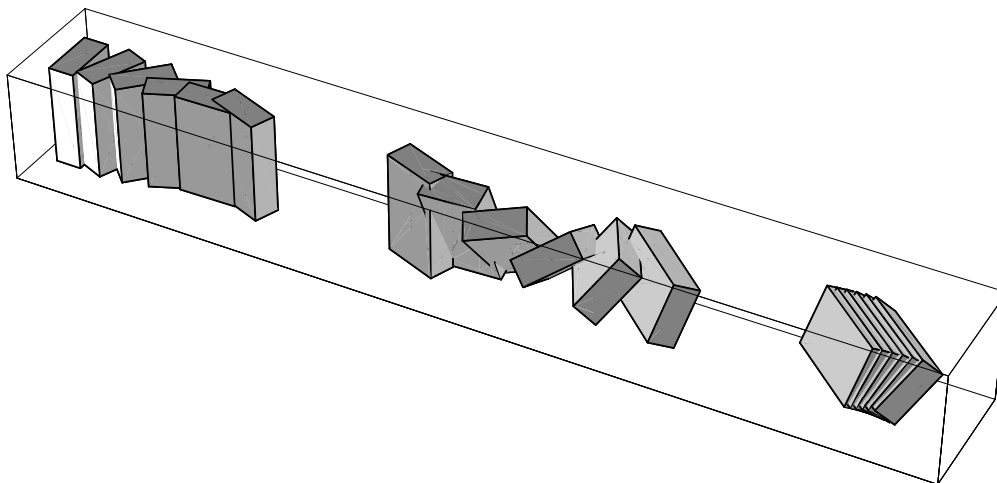

**Inverse-kinematic planner for  $\Sigma_1$ -systems SE(2)** First class of underactuated controllable system on SE(2) is

$$\Sigma_1 = \{(V_1, V_2) \mid V_1 = (1, b_1, c_1), V_2 = (0, b_2, c_2), b_2^2 + c_2^2 = 1\}$$

*Motion Algorithm:* given  $(\theta, x, y)$ , flow along  $(V_1, V_2, V_1)$  for coasting times

$$(t_1, t_2, t_3) = (\text{atan2}(\alpha, \beta), \rho, \theta - \text{atan2}(\alpha, \beta))$$

where  $\rho = \sqrt{\alpha^2 + \beta^2}$  and 
$$\begin{bmatrix} \alpha \\ \beta \end{bmatrix} = \begin{bmatrix} b_2 & c_2 \\ -c_2 & b_2 \end{bmatrix} \left( \begin{bmatrix} x \\ y \end{bmatrix} - \begin{bmatrix} -c_1 & b_1 \\ b_1 & c_1 \end{bmatrix} \begin{bmatrix} 1 - \cos \theta \\ \sin \theta \end{bmatrix} \right)$$

**Identity Map =**  $(\theta, x, y) \xrightarrow{\mathcal{JK}} (t_1, t_2, t_3) \xrightarrow{\mathcal{FK}} \exp(t_1 V_1) \exp(t_2 V_2) \exp(t_3 V_1)$

**Inverse-kinematic planner for  $\Sigma_2$ -systems SE(2)** Second and last class of underactuated controllable system on SE(2):

$$\Sigma_2 = \{(V_1, V_2) \mid V_1 = (1, b_1, c_1), V_2 = (1, b_2, c_2), b_1 \neq b_2 \text{ or } c_1 \neq c_2\}$$

*Motion Algorithm:* given  $(\theta, x, y)$ , flow along  $(V_1, V_2, V_1)$  for coasting times

$$t_1 = \text{atan2}\left(\rho, \sqrt{4 - \rho^2}\right) + \text{atan2}(\alpha, \beta) \quad t_2 = \text{atan2}\left(2 - \rho^2, \rho\sqrt{4 - \rho^2}\right)$$

$$t_3 = \theta - t_1 - t_2$$

where  $\rho = \sqrt{\alpha^2 + \beta^2}$ , 
$$\begin{bmatrix} \alpha \\ \beta \end{bmatrix} = \begin{bmatrix} c_1 - c_2 & b_2 - b_1 \\ b_1 - b_2 & c_1 - c_2 \end{bmatrix} \left( \begin{bmatrix} x \\ y \end{bmatrix} - \begin{bmatrix} -c_1 & b_1 \\ b_1 & c_1 \end{bmatrix} \begin{bmatrix} 1 - \cos \theta \\ \sin \theta \end{bmatrix} \right)$$

**Local Identity Map =**  $(\theta, x, y) \xrightarrow{\mathcal{JK}} (t_1, t_2, t_3) \xrightarrow{\mathcal{FK}} \exp(t_1 V_1) \exp(t_2 V_2) \exp(t_3 V_1)$

### Inverse-kinematic planners on SE(2): simulation

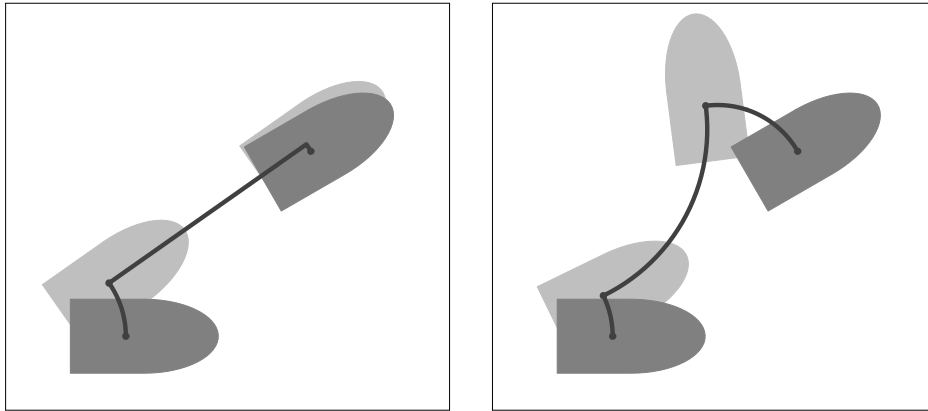

Inverse-kinematics planners for sample systems in  $\Sigma_1$  and  $\Sigma_2$ . The systems parameters are  $(b_1, c_1) = (0, .5)$ ,  $(b_2, c_2) = (1, 0)$ . The target location is  $(\pi/6, 1, 1)$ .

### Inverse-kinematic planners on SE(2): snakeboard simulation

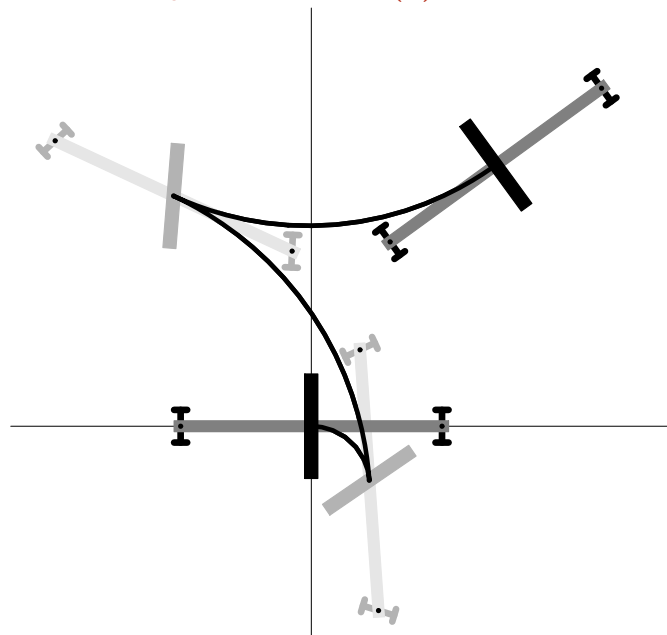

snakeboard as  $\Sigma_2$ -system

**Inverse-kinematic planners on  $SE(2) \times \mathbb{R}$ : simulation** 4 dof system in  $\mathbb{R}^3$ , no pitch no roll

kinematically controllable via body-fixed constant velocity fields:

$V_1$ = rise and rotate about inertial point;  $V_2$ = translate forward and dive

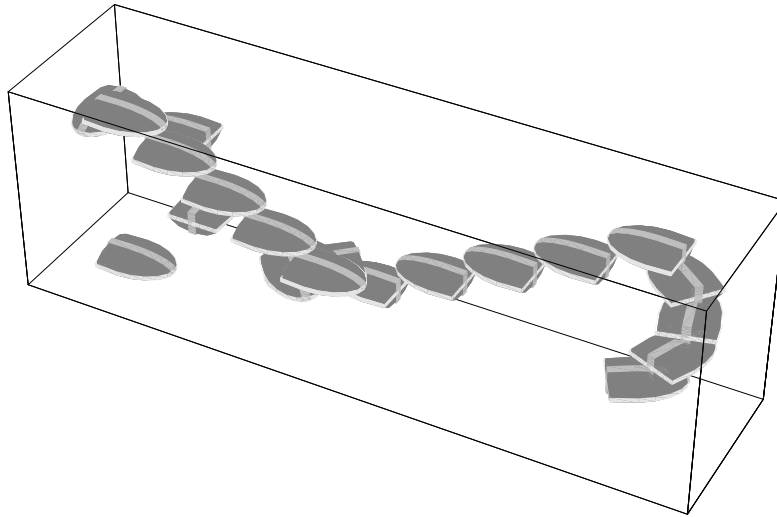

The target location is  $(\pi/6, 10, 0, 1)$

**Inverse-kinematic planners on  $SE(3)$ : simulation**

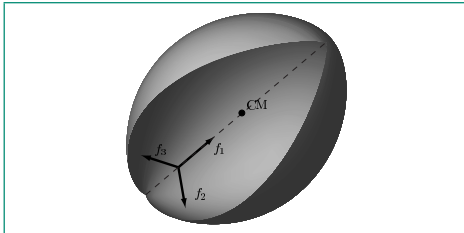

kinematically controllable via

body-fixed constant velocity fields:

$V_1$  = translation along 1st axis

$V_2$  = rotation about 2nd axis

$V_3$  = rotation about 3rd axis

$V_3 : 0 \rightarrow 1$ : rotation about 3rd axis  
 $V_2 : 1 \rightarrow 2$ : rotation about 2nd axis  
 $V_1 : 2 \rightarrow 3$ : translation along 1st axis  
 $V_3 : 3 \rightarrow 4$ : rotation about 3rd axis  
 $V_2 : 4 \rightarrow 5$ : rotation about 2nd axis  
 $V_3 : 5 \rightarrow 6$ : rotation about 3rd axis

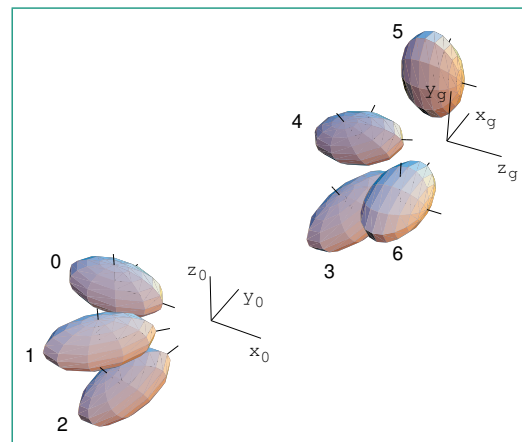

## Summary

- relationship between trajectories of dynamic and of kinematic models of mechanical systems
- kinematic reductions (multiple, low rank), and maximally reducible systems
- controllability mechanisms, e.g., STLC vs kinematic controllability
- systems on matrix Lie groups
- inverse-kinematics planners

## Analysis and design of oscillatory controls for ACCS

1. Introduction to Averaging
2. Survey of averaging results
3. Two-time scale averaging analysis for mechanical systems
4. Analysis via the Averaged Potential
5. Control design via Inversion Lemma
6. Tracking results and examples

## Introduction to averaging

- Oscillations play key role in animal and robotic locomotion
- oscillations generate motion in Lie bracket directions useful for trajectory design
- objective is to study oscillatory controls in mechanical systems:

$$\nabla_{\gamma'(t)} \gamma'(t) = Y(t, \gamma(t)), \quad \int_0^T Y(t, q) dt = 0, \quad q \in \mathbb{Q}.$$

- **oscillatory signals:** periodic large-amplitude, high-frequency

## Survey of results on averaging

- **Early developments:** Lagrange, Jacobi, Poincaré
- **Oscillatory Theory:**
  - *Dynamical Systems:* Bogoliubov Mitropolsky, Guckenheimer Holmes, Sanders Verhulst, ...
  - *Control Systems:* Bloch, Khalil ...
- **Related Work:**
  - *General ODE's:* Kurzweil-Jarnik, Sussmann-Liu,
  - *(Electro)Mechanical Systems:* Hill, Mathieu, Bailleul, Kapitsa, Levi ...
  - *Series Expansions:* Magnus, Chen, Brockett, Gilbert, Sussmann, Kawski ...
  - *Time-dependent vector fields:* Agrachev, Gramkrelidze, ...
  - *Small-amplitude averaging and high-order averaging:* Sarychev, Vela, ...

### Averaging for systems in standard form

- for  $\epsilon > 0$ , system in **standard form**

$$\gamma'(t) = \epsilon X(t, \gamma(t)), \quad \gamma(0) = x_0$$

- assume  $X$  is  $T$ -periodic, define the **averaged vector field**

$$\bar{X}(x) = \frac{1}{T} \int_0^T X(\tau, x) d\tau.$$

- define the **averaged trajectory**  $t \mapsto \eta(t) \in M$  by

$$\eta'(t) = \epsilon \bar{X}(\eta(t)), \quad \eta(0) = x_0$$

### Theorem 30 (First-order Averaging Theorem)

$$\gamma(t) - \eta(t) = O(\epsilon) \quad \text{for all } t \in [0, \frac{t_0}{\epsilon}]$$

If  $\bar{X}$  has linearly asymptotically stable point, then estimate holds for all time

### Averaging for systems in standard oscillatory form

- for  $\epsilon > 0$ , system in **standard oscillatory form**

$$\gamma'(t) = X(t, \gamma(t)) + \frac{1}{\epsilon} Y\left(\frac{t}{\epsilon}, t, \gamma(t)\right), \quad \gamma(0) = x_0$$

- Assumptions:

1.  $Y$  is  $T$ -periodic and zero-mean in first argument
2. the vector fields  $x \mapsto Y(\tau, t, x)$ , at fixed  $(\tau, t)$ , are commutative

- Useful constructions:

1. given diffeomorphism  $\phi$  and vector field  $X$ , the **pull-back vector field**  
 $\phi^* X = T\phi^{-1} \circ X \circ \phi$
2. given **extended state**  $x_e = (t, x)$ , define  $X_e(x_e) = (1, X(x_e))$ , and  
 $Y_e(\tau, x_e) = (0, Y(\tau, x_e))$
3. define  $F$  as two-time scale vector field by

$$(1, F(\tau, x_e)) = \left( (\Phi_{0,\tau}^{Y_e})^* X_e \right)(x_e)$$

### Averaging for systems in standard oscillatory form: cont'd

- define  $\bar{F}$  as average with respect to  $\tau$
- for fixed  $\lambda_0$ , compute the trajectories

$$\begin{aligned}\xi'(t) &= \bar{F}(t, \xi(t)) \\ \eta'(t, \lambda_0) &= Y(t, \lambda_0, \eta(t))\end{aligned}$$

with initial conditions:  $\xi(0) = x_0$  and  $\eta(0) = \xi(0)$   
 (note  $\tau \mapsto \eta(\tau, t)$  equals  $\xi(t)$  plus zero-mean oscillation)

### Theorem 31 (Oscillatory Averaging Theorem)

$$\gamma(t) - \eta(t/\epsilon, t) = O(\epsilon) \quad \text{for all } t \in [0, t_0]$$

### Two-time scale averaging for mechanical systems

- for  $\epsilon \in \mathbb{R}_+$ , consider the forced ACCS  $(Q, \nabla, Y, \mathcal{D}, \mathcal{Y} = \{Y_1, \dots, Y_m\}, \mathbb{R}^m)$ :

$$\nabla_{\gamma'(t)} \gamma'(t) = Y(t, \gamma'(t)) + \sum_{a=1}^m \frac{1}{\epsilon} u^a \left( \frac{t}{\epsilon}, t \right) Y_a(\gamma(t))$$

where  $Y$  is an affine map of the velocities

- assume the two-time scale inputs  $u = (u^1, \dots, u^m): \bar{\mathbb{R}}_+ \times \bar{\mathbb{R}}_+ \rightarrow \mathbb{R}^m$  are  $T$ -periodic and zero-mean in their first argument
- define the symmetric positive-definite curve  $\Lambda: \bar{\mathbb{R}}_+ \rightarrow \mathbb{R}^{m \times m}$  by

$$\Lambda_{ab}(t) = \frac{1}{2} (\overline{U_{(a)} U_{(b)}}(t) - \overline{U_{(a)}}(t) \overline{U_{(b)}}(t)), \quad a, b \in \{1, \dots, m\}$$

where

$$U_{(a)}(\tau, t) = \int_0^\tau u_a(s, t) ds, \quad \overline{U_{(a)}}(t) = \frac{1}{T} \int_0^T U_{(a)}(\tau, t) d\tau$$

- define the **averaged ACCS**

$$\nabla_{\xi'(t)} \xi'(t) = Y(t, \xi'(t)) - \sum_{a,b=1}^m \Lambda_{ab}(t) \langle Y_a : Y_b \rangle (\xi(t))$$

with initial condition

$$\xi'(0) = \gamma'(0) + \sum_{a=1}^m \bar{U}_{(a)}(0) Y_a(\gamma(0))$$

**Theorem 32 (Oscillatory Averaging Theorem for ACCS)** *there exists  $\epsilon_0, t_0 \in \mathbb{R}_+$  such that, for all  $t \in [0, t_0]$  and for all  $\epsilon \in (0, \epsilon_0)$ ,*

$$\begin{aligned} \gamma(t) &= \xi(t) + O(\epsilon), \\ \gamma'(t) &= \xi'(t) + \sum_{a=1}^m \left( U_{(a)}\left(\frac{t}{\epsilon}, t\right) - \bar{U}_{(a)}(t) \right) Y_a(\xi(t)) + O(\epsilon). \end{aligned}$$

If oscillatory inputs depend only on fast time, and if the averaged ACCS has linearly asymptotically stable equilibrium configuration, then estimate holds for all time

### Averaging analysis with potential control forces

- **when is the averaged system again a simple mechanical system?**
- consider simple mechanical control system  $(Q, \mathbb{G}, V, F_{\text{diss}}, \mathcal{F}, \mathbb{R}^m)$ 
  1. no constraints
  2.  $\mathcal{F} = \{d\phi^1, \dots, d\phi^m\}$ , where  $\phi^a : Q \rightarrow \mathbb{R}$  for  $a \in \{1, \dots, m\}$
  3.  $F_{\text{diss}}$  is linear in velocity
- define input vector fields

$$Y_a(q) = \text{grad } \phi^a(q), \quad (\text{grad } \phi^a)^i = \mathbb{G}^{ij} \frac{\partial \phi^a}{\partial q^j}$$

**Lemma 33** *symmetric product between vector fields satisfies*

$$\langle \text{grad } \phi^a : \text{grad } \phi^b \rangle = \text{grad } \langle \phi^a : \phi^b \rangle$$

where symmetric product between functions (Beltrami bracket) is:

$$\langle \phi^a : \phi^b \rangle = \langle d\phi^a, d\phi^b \rangle = \mathbb{G}^{ij} \frac{\partial \phi^a}{\partial q^i} \frac{\partial \phi^b}{\partial q^j}$$

### Averaging via the averaged potential

$$\begin{aligned} \mathbb{G}_{\gamma'(t)} \gamma'(t) &= -\text{grad } V(\gamma(t)) + \mathbb{G}^\#(F_{\text{diss}}(\gamma'(t))) \\ &\quad + \sum_{a=1}^m \frac{1}{\epsilon} u^a \left(\frac{t}{\epsilon}\right) \text{grad}(\phi^a)(\gamma(t)), \end{aligned}$$



$$\begin{aligned} \mathbb{G}_{\xi'(t)} \xi'(t) &= -\text{grad } V_{\text{avg}}(\xi(t)) + \mathbb{G}^\#(F_{\text{diss}}(\xi'(t))) \\ V_{\text{avg}} &= V + \sum_{a,b=1}^m \Lambda_{ab} \langle \phi^a : \phi^b \rangle. \end{aligned}$$

### Example: stabilizing a two-link manipulator via oscillations

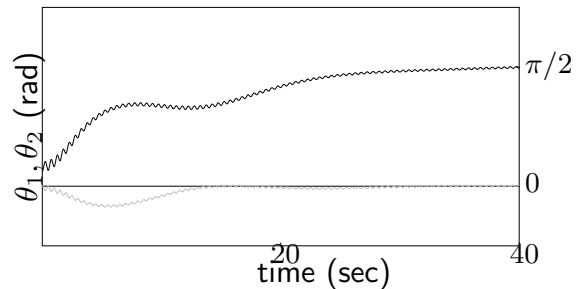
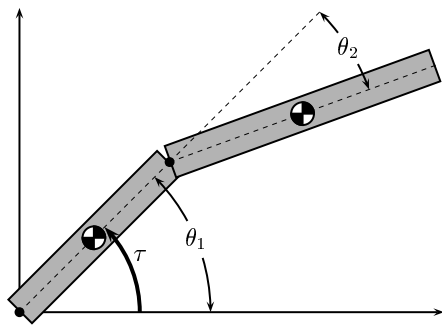

$$u = -\theta_1 + \frac{1}{\epsilon} \cos\left(\frac{t}{\epsilon}\right)$$

Two-link damped manipulator with oscillatory control at first joint. The averaging analysis predicts the behavior. (the gray line is  $\theta_1$ , the black line is  $\theta_2$ ).

## Summary

- averaging theorem for standard form
- averaging theorem for standard oscillatory form
- averaging for mechanical systems with oscillatory controls
- analysis via the averaged potential

## Design of oscillatory controls via approximate inversion

- Objective: design oscillatory control laws for ACCS
- stabilization and tracking for systems that are not linearly controllable
- setup: consider ACCS  $(Q, \nabla, Y, \mathcal{D}, \mathcal{Y} = \{Y_1, \dots, Y_m\}, \mathbb{R}^m)$  where  $Y$  is an affine map of the velocities
- define **averaging product**  $\mathcal{A}_{[0,T]}$  as the map taking a pair of two-time scale vector fields into a time-dependent vector field by

$$\begin{aligned} \mathcal{A}_{[0,T]}(V, W)(t, q) = & -\frac{1}{2T} \int_0^T \left\langle \int_0^{\tau_1} V(\tau_2, t, q) d\tau_2 : \int_0^{\tau_1} W(\tau_2, t, q) d\tau_2 \right\rangle d\tau_1 \\ & + \frac{1}{2T^2} \left\langle \int_0^T \int_0^{\tau_1} V(\tau_2, t, q) d\tau_2 d\tau_1 : \int_0^T \int_0^{\tau_1} W(\tau_2, t, q) d\tau_2 d\tau_1 \right\rangle. \end{aligned}$$

### Basis-free restatement of averaging theorem

**Corollary 34** For  $\epsilon \in \mathbb{R}_+$ , consider governing equations

$$\nabla_{\gamma'(t)} \gamma'(t) = Y(t, \gamma'(t)) + \frac{1}{\epsilon} W\left(\frac{t}{\epsilon}, t, \gamma(t)\right),$$

- (i)  $W$  takes values in  $\mathcal{Y}$
- (ii)  $q \mapsto W(\tau, t, q)$ , for  $(\tau, t) \in \bar{\mathbb{R}}_+ \times \bar{\mathbb{R}}_+$ , are commutative

Then, the averaged forced affine connection system is

$$\nabla_{\xi'(t)} \xi'(t) = Y(t, \xi'(t)) + \mathcal{A}_{[0, T]}(W, W)(t, \xi(t))$$

**Problem 35 (Inversion Objective)** Given any time-dependent vector field  $X$ , compute two vector fields taking values in  $\mathcal{Y}$

1.  $W_{X, \text{slow}}$  is time-dependent
2.  $W_{X, \text{osc}}$  is two-time scales, periodic and zero-mean in fast time scale

such that

$$W_{X, \text{slow}} + \mathcal{A}_{[0, T]}(W_{X, \text{osc}}, W_{X, \text{osc}}) = X \quad (1)$$

### Controllability assumption and constructions

- **Controllability Assumption:** for all  $a \in \{1, \dots, m\}$ ,  $\langle Y_a : Y_a \rangle \in \mathcal{Y}$
- (i) smooth functions  $\sigma_a^b$ ,  $a, b \in \{1, \dots, m\}$ , such that, for all  $a \in \{1, \dots, m\}$

$$\langle Y_a : Y_a \rangle = \sum_{b=1}^m \sigma_a^b Y_b$$

- (ii) for  $T \in \mathbb{R}_+$  and  $i \in \mathbb{N}$ , define  $\varphi_i: \mathbb{R} \rightarrow \mathbb{R}$  by

$$\varphi_i(t) = \frac{4\pi i}{T} \cos\left(\frac{2\pi i}{T} t\right)$$

- (iii) define the **lexicographic ordering** as the bijective map  $\text{lo}: \{(a, b) \in \{1, \dots, m\}^2 \mid a < b\} \rightarrow \{1, \dots, \frac{1}{2}m(m-1)\}$  given by  $\text{lo}(a, b) = \sum_{j=1}^{a-1} (m-j) + (b-a)$

## Inversion algorithm

- For an ACCS with Controllability Assumption, assume

$$X(t, q) = \sum_{a=1}^m \eta^a(t, q) Y_a(q) + \sum_{\substack{b,c=1, \\ b < c}}^m \eta^{bc}(t, q) \langle Y_b : Y_c \rangle(q)$$

- Then **Inversion Objective** (1) is solved by

$$W_{X,\text{slow}}(t, q) = \sum_{a=1}^m u_{X,\text{slow}}^a(t, q) Y_a(q), \quad W_{X,\text{osc}}(\tau, t, q) = \sum_{a=1}^m u_{X,\text{osc}}^a(\tau, t, q) Y_a(q)$$

where

$$\begin{aligned} u_{X,\text{slow}}^a(t, q) &= \eta^a(t, q) + \sum_{b=1}^m \left( b - 1 + \sum_{i=b+1}^m \frac{(\eta^{bi}(t, q))^2}{4} \right) \sigma_b^a(q) \\ &\quad + \sum_{b=a+1}^m \left( \frac{1}{2} \eta^{ab} (\mathcal{L}_{Y_a} \eta^{ab}) - \mathcal{L}_{Y_b} \eta^{ab} \right)(t, q), \\ u_{X,\text{osc}}^a(\tau, t, q) &= \sum_{i=1}^{a-1} \varphi_{\text{lo}(i,a)}(\tau) - \frac{1}{2} \sum_{i=a+1}^m \eta^{ai}(t, q) \varphi_{\text{lo}(a,i)}(\tau) \end{aligned}$$

## Tracking via oscillatory controls

Consider ACCS  $(Q, \nabla, Y, \mathcal{D} = \text{TQ}, \mathcal{Y} = \{Y_1, \dots, Y_m\}, \mathbb{R}^m)$  satisfying Controllability Assumption and  $\text{span} \{Y_a, \langle Y_b : Y_c \rangle \mid a, b, c \in \{1, \dots, m\}\} = \text{TQ}$

**Problem 36 (Vibrational Tracking)** given reference  $\gamma_{\text{ref}}$ , find oscillatory controls such that closed-loop trajectory equals  $\gamma_{\text{ref}}$  up to an error of order  $\epsilon$

Vibrational tracking is achieved by oscillatory state feedback

$$\begin{aligned} u_{X,\text{slow}}^a(t, v_q) &= u_{\text{ref}}^a(t) + \sum_{b=1}^m \left( b - 1 + \sum_{c=b+1}^m \frac{(u_{\text{ref}}^{bc}(t))^2}{4} \right) \sigma_b^a(q), \\ u_{X,\text{osc}}^a(\tau, t, v_q) &= \sum_{c=1}^{a-1} \varphi_{\text{lo}(c,a)}(\tau) - \frac{1}{2} \sum_{c=a+1}^m u_{\text{ref}}^{ac}(t) \varphi_{\text{lo}(a,c)}(\tau) \end{aligned}$$

where the **fictitious inputs** are defined by

$$\nabla_{\gamma'_{\text{ref}}(t)} \gamma'_{\text{ref}}(t) - Y(t, \gamma'_{\text{ref}}(t)) = \sum_{a=1}^m u_{\text{ref}}^a(t) Y_a(\gamma_{\text{ref}}(t)) + \sum_{\substack{b,c=1 \\ b < c}}^m u_{\text{ref}}^{bc}(t) \langle Y_b : Y_c \rangle(\gamma_{\text{ref}}(t))$$

**Example: A second-order nonholonomic integrator** Consider

$$\ddot{x}_1 = u_1, \quad \ddot{x}_2 = u_2, \quad \ddot{x}_3 = u_1 x_2 + u_2 x_1,$$

Controllability assumption ok. Design controls to track  $(x_1^d(t), x_2^d(t), x_3^d(t))$ :

$$u_1 = \ddot{x}_1^d + \frac{1}{\sqrt{2}\epsilon} \left( \ddot{x}_3^d - \ddot{x}_1^d x_2^d - \ddot{x}_2^d x_1^d \right) \cos\left(\frac{t}{\epsilon}\right)$$

$$u_2 = \ddot{x}_2^d - \frac{\sqrt{2}}{\epsilon} \cos\left(\frac{t}{\epsilon}\right)$$

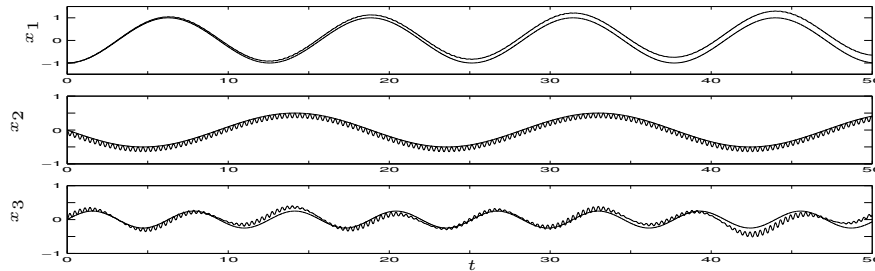

**Example: A planar vertical takeoff and landing (PVTOL) aircraft**

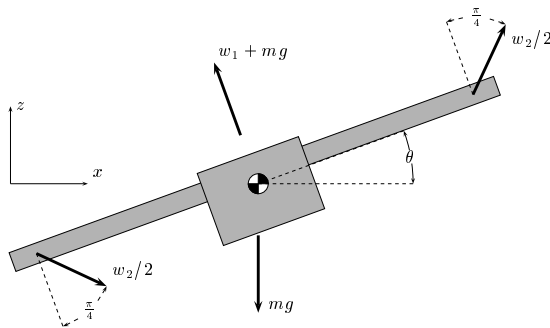

$$\dot{x} = \cos \theta v_x - \sin \theta v_z$$

$$\dot{z} = \sin \theta v_x + \cos \theta v_z$$

$$\dot{\theta} = \omega$$

$$\dot{v}_x - v_z \omega = -g \sin \theta + (-k_1/m)v_x + (1/m)u_2$$

$$\dot{v}_z + v_x \omega = -g(\cos \theta - 1) + (-k_2/m)v_z + (1/m)u_1$$

$$\dot{\omega} = (-k_3/J)\omega + (h/J)u_2$$

$Q = SE(2)$  : Configuration and velocity space via  $(x, z, \theta, v_x, v_z, \omega)$ .  $x$  and  $z$  are horizontal and vertical displacement,  $\theta$  is roll angle. The angular velocity is  $\omega$  and the linear velocities in the body-fixed  $x$  (respectively  $z$ ) axis are  $v_x$  (respectively  $v_z$ ).

$u_1$  is body vertical force minus gravity,  $u_2$  is force on the wingtips (with a net horizontal component).  $k_i$ -components are linear damping force,  $g$  is gravity constant. The constant  $h$  is the distance from the center of mass to the wingtip,  $m$  and  $J$  are mass and moment of inertia.

## Oscillatory controls ex. #2: PVTOL model

Controllability assumption ok. Design controls to track  $(x^d(t), z^d(t), \theta^d(t))$ :

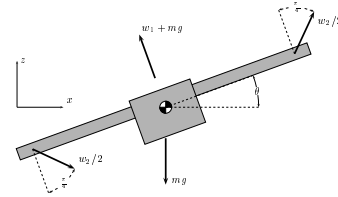

$$u_1 = \frac{J}{h} \ddot{\theta}^d + \frac{k_3}{h} \dot{\theta}^d - \frac{\sqrt{2}}{\epsilon} \cos\left(\frac{t}{\epsilon}\right)$$

$$u_2 = \frac{h}{J} - f_1 \sin \theta^d + f_2 \cos \theta^d - \frac{J\sqrt{2}}{h\epsilon} (f_1 \cos \theta^d + f_2 \sin \theta^d) \cos\left(\frac{t}{\epsilon}\right),$$

where we let  $c = \frac{J}{h} \ddot{\theta}^d + \frac{k_3}{h} \dot{\theta}^d$  and

$$f_1 = m\ddot{x}^d + (k_1 \cos^2 \theta^d + k_2 \sin^2 \theta^d) \dot{x}^d + \frac{\sin(2\theta^d)}{2} (k_1 - k_2) \dot{z}^d + mg \sin \theta^d - c \cos \theta^d,$$

$$f_2 = m\ddot{z}^d + \frac{\sin(2\theta^d)}{2} (k_1 - k_2) \dot{x}^d + (k_1 \sin^2 \theta^d + k_2 \cos^2 \theta^d) \dot{z}^d + mg(1 - \cos \theta^d) - c \sin \theta^d.$$

## PVTOL simulations: trajectories and error

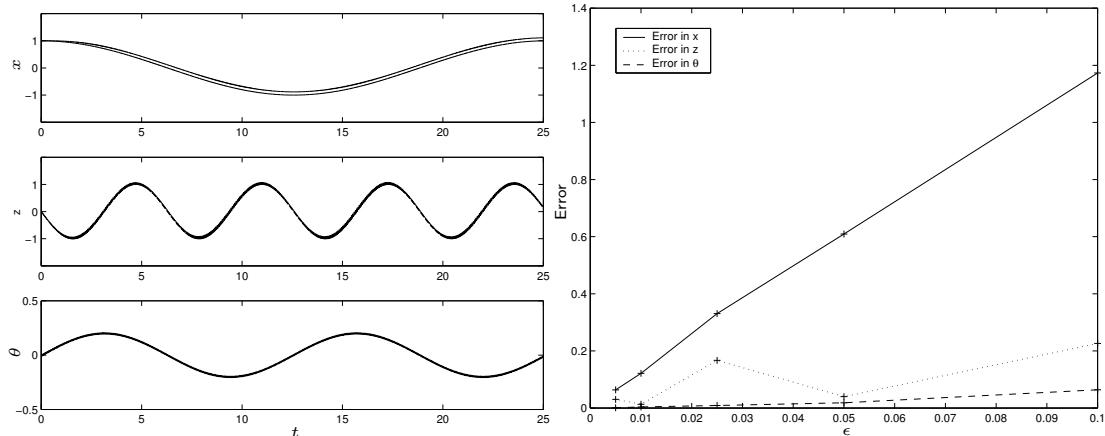

Trajectory design at  $\epsilon = .01$ .

Tracking errors at  $t = 10$ .

## Summary

- averaging theorem for standard form
- averaging theorem for standard oscillatory form
- averaging for mechanical systems with oscillatory controls
- analysis via the averaged potential
- inversion based on controllability
- fairly complete solution to stabilization and tracking problems

## Summary

1. Introduction
2. Modeling of simple mechanical systems
3. Controllability
4. Kinematic reductions and motion planning
5. Analysis and design of oscillatory controls
6. Open problems. . .

## Open problems

### Modeling

1. variable-rank distributions in nonholonomic mechanics
2. affine nonholonomic constraints
3. Riemannian geometry of systems with symmetry
4. infinite-dimensional systems
5. control forces that are not basic
6. tractable symbolic models for systems with many degrees of freedom

### Controllability

1. linear controllability of systems with gyroscopic and/or dissipative forces
2. controllability along relative equilibria
3. accessibility from non-zero initial conditions
4. weaker sufficient conditions for controllability

### **Kinematic reductions and motion planning**

1. understanding when the kinematic reduction allows for low-complexity calculation of motion plans for underactuated systems
2. motion planning with locality constraints
3. relationship with theory of consistent abstractions
4. feedback control to stabilize trajectories of the kinematic reductions
5. design of stabilization algorithms based on kinematic reductions

### **Analysis and design of oscillatory controls**

1. series expansions from non-zero initial conditions
2. motion planning algorithms based on small-amplitude controls
3. higher-order averaging and inversion + relationship with higher order controllability
4. analysis of locomotion gaits

## References

- Abraham, R. and Marsden, J. E. [1978] *Foundations of Mechanics*, second edition, Addison Wesley, Reading, MA, ISBN 0-8053-0102-X.
- Agrachev, A. A. and Sachkov, Y. [2004] *Control Theory from the Geometric Viewpoint*, volume 87 of *Encyclopaedia of Mathematical Sciences*, Springer-Verlag, New York–Heidelberg–Berlin, ISBN 3-540-21019-9.
- Arimoto, S. [1996] *Control Theory of Non-linear Mechanical Systems: A Passivity-Based and Circuit-Theoretic Approach*, number 49 in Oxford Engineering Science Series, Oxford University Press, Walton Street, Oxford, ISBN 0-19-856291-8.
- Arnol'd, V. I. [1978] *Mathematical Methods of Classical Mechanics*, first edition, number 60 in Graduate Texts in Mathematics, Springer-Verlag, New York–Heidelberg–Berlin, ISBN 0-387-90314-3, second edition: [Arnol'd 1989].
- [1989] *Mathematical Methods of Classical Mechanics*, second edition, number 60 in Graduate Texts in Mathematics, Springer-Verlag, New York–Heidelberg–Berlin, ISBN 0-387-96890-3.
- Baillieul, J. [1993] *Stable average motions of mechanical systems subject to periodic forcing*, in *Dynamics and Control of Mechanical Systems (Waterloo, Canada)*, M. J. Enos, editor, volume 1, pages 1–23, Fields Institute, Waterloo, Canada, ISBN 0-821-89200-2.
- Bates, L. M. and Śniatycki, J. Z. [1993] *Nonholonomic reduction*, Reports on Mathematical Physics, **32**(1), 444–452.
- Bloch, A. M. [2003] *Nonholonomic Mechanics and Control*, volume 24 of *Interdisciplinary Applied Mathematics*, Springer-Verlag, New York–Heidelberg–Berlin, ISBN 0-387-095535-6.
- Bloch, A. M., Chang, D. E., Leonard, N. E., and Marsden, J. E. [2001] *Controlled Lagrangians and the stabilization of mechanical systems. II. Potential shaping*, IEEE Transactions on Automatic Control, **46**(10), 1556–1571.
- Bloch, A. M. and Crouch, P. E. [1992] *Kinematics and dynamics of nonholonomic control systems on Riemannian manifolds*, in *Proceedings of the 32nd IEEE Conference on Decision and Control*, pages 1–5, Tucson, AZ.
- Bloch, A. M., Krishnaprasad, P. S., Marsden, J. E., and Murray, R. M. [1996] *Nonholonomic mechanical systems with symmetry*, Archive for Rational Mechanics and Analysis, **136**(1), 21–99.

- Bloch, A. M., Leonard, N. E., and Marsden, J. E. [2000] *Controlled Lagrangians and the stabilization of mechanical systems. I. The first matching theorem*, IEEE Transactions on Automatic Control, **45**(12), 2253–2270.
- Bloch, A. M., Reyhanoglu, M., and McClamroch, N. H. [1992] *Control and stabilization of nonholonomic dynamic systems*, IEEE Transactions on Automatic Control, **37**(11), 1746–1757.
- Bonnard, B. [1984] *Contrôlabilité de systèmes mécaniques sur les groupes de Lie*, SIAM Journal on Control and Optimization, **22**(5), 711–722.
- Brockett, R. W. [1977] *Control theory and analytical mechanics*, in *The 1976 Ames Research Center (NASA) Conference on Geometric Control Theory (Moffett Field, CA)*, C. Martin and R. Hermann, editors, pages 1–48, Math Sci Press, Brookline, MA, ISBN 0-915692-721-X.
- Bullo, F. [2001] *Series expansions for the evolution of mechanical control systems*, SIAM Journal on Control and Optimization, **40**(1), 166–190.
- [2002] *Averaging and vibrational control of mechanical systems*, SIAM Journal on Control and Optimization, **41**(2), 542–562.
- Bullo, F. and Lewis, A. D. [2003] *Low-order controllability and kinematic reductions for affine connection control systems*, SIAM Journal on Control and Optimization, to appear.
- Bullo, F. and Lynch, K. M. [2001] *Kinematic controllability and decoupled trajectory planning for underactuated mechanical systems*, IEEE Transactions on Robotics and Automation, **17**(4), 402–412.
- Crouch, P. E. [1981] *Geometric structures in systems theory*, IEE Proceedings. D. Control Theory and Applications, **128**(5), 242–252.
- Godbillon, C. [1969] *Géométrie Différentielle et Mécanique Analytique*, Collection Méthodes. Mathématique, Hermann, Paris.
- Jurdjevic, V. [1997] *Geometric Control Theory*, number 51 in Cambridge Studies in Advanced Mathematics, Cambridge University Press, New York–Port Chester–Melbourne–Sydney, ISBN 0-521-49502-4.
- Koiller, J. [1992] *Reduction of some classical nonholonomic systems with symmetry*, Archive for Rational Mechanics and Analysis, **118**(2), 113–148.
- Lewis, A. D. and Murray, R. M. [1997] *Controllability of simple mechanical control systems*, SIAM Journal on Control and Optimization, **35**(3), 766–790.
- Martínez, S., Cortés, J., and Bullo, F. [2003] *Analysis and design of oscillatory control systems*, IEEE Transactions on Automatic Control, **48**(7), 1164–1177.

- Nijmeijer, H. and van der Schaft, A. J. [1990] *Nonlinear Dynamical Control Systems*, Springer-Verlag, New York–Heidelberg–Berlin, ISBN 0-387-97234-X.
- Ortega, R., Loria, A., Nicklasson, P. J., and Sira-Ramirez, H. [1998] *Passivity-Based Control of Euler-Lagrange Systems: Mechanical, Electrical and Electromechanical Applications*, Communications and Control Engineering Series, Springer-Verlag, New York–Heidelberg–Berlin, ISBN 1-85233-016-3.
- Ortega, R., Spong, M. W., Gómez-Estern, F., and Blankenstein, G. [2002] *Stabilization of a class of underactuated mechanical systems via interconnection and damping assignment*, IEEE Transactions on Automatic Control, **47**(8), 1218–1233.
- Synge, J. L. [1928] *Geodesics in nonholonomic geometry*, Mathematische Annalen, **99**, 738–751.
- Takegaki, M. and Arimoto, S. [1981] *A new feedback method for dynamic control of manipulators*, Transactions of the ASME. Series G. Journal of Dynamic Systems, Measurement, and Control, **103**(2), 119–125.
- van der Schaft, A. J. [1981/82] *Hamiltonian dynamics with external forces and observations*, Mathematical Systems Theory, **15**(2), 145–168.
- [1982] *Controllability and observability of affine nonlinear Hamiltonian systems*, IEEE Transactions on Automatic Control, **27**(2), 490–492.
- [1983] *Symmetries, conservation laws, and time reversibility for Hamiltonian systems with external forces*, Journal of Mathematical Physics, **24**(8), 2095–2101.
- [1985] *Controlled invariance for Hamiltonian systems*, Mathematical Systems Theory, **18**(3), 257–291.
- [1986] *Stabilization of Hamiltonian systems*, Nonlinear Analysis. Theory, Methods, and Applications, **10**(10), 1021–1035.
- van der Schaft, A. J. and Maschke, B. M. [1994] *On the Hamiltonian formulation of nonholonomic mechanical systems*, Reports on Mathematical Physics, **34**(2), 225–233.